

GDL 90 UAT Data Link Sensor

Installation Manual

November 2004
560-1049-01 Rev. A



© 2004 Garmin Ltd. or its subsidiaries. All rights reserved. Printed in the U.S.A.

Garmin International, Inc., 1200 East 151st Street, Olathe Kansas 66062, U.S.A.
Tel: 913/397.8200 Fax: 913/397.8282

Garmin (Europe) Ltd., Unit 5, The Quadrangle, Abbey Park Industrial Estate, Romsey, Hampshire S051
9DL, U.K.
Tel: 44/1794.519944 Fax: 44/1794.519222

Garmin Corporation, No. 68, Jangshu 2nd Road, Shijr, Taipei County, Taiwan
Tel: 886/02.2642.9199 Fax: 886/02.2642.9099

Garmin AT, Inc., 2345 Turner Road, S.E., Salem, OR 97302, U.S.A.
Tel: 800/525.6726 Fax: 503/364.2138
Canada Tel: 800/654.3415
International Tel: 503/391.3411

Cage Code: 0XCJ6

Visit our web page at <http://www.garmin.com>

Send comments about this manual by email to: techpubs.salem@garmin.com

Except as expressly provided herein, no part of this manual may be reproduced, copied, transmitted, disseminated, downloaded or stored in any storage medium, for any purpose without the express written permission of Garmin. Garmin hereby grants permission to download a single copy of this manual and of any revision to this manual onto a hard drive or other electronic storage medium to be viewed for personal use, provided that such electronic or printed copy of this manual or revision must contain the complete text of this copyright notice and provided further that any unauthorized commercial distribution of this manual or any revision hereto is strictly prohibited.

Information in this document is subject to change without notice. Garmin reserves the right to change or improve their products and to make changes in the content of this material without obligation to notify any person or organization of such changes or improvements.

Garmin®, Garmin AT®, and GDL are trademarks of Garmin Ltd. or its subsidiaries. These trademarks may not be used without the express permission of Garmin.

HISTORY OF REVISIONS

Revision	Date	Description
-00 --	3/17/04	Initial release
-00 A	4/07/04	Update environmental categories (1.3.3, A.1), FCC waiver (1.4.3), APM p/n (Table 1-3). Add missing lines (Figure 2-1), APM weight (Table 2-6), APM environmental qualification form (A.2).
-00 B	4/30/04	Remove “STC Pending watermark”. Clarify output of data (1.2). Add transmitter caution (1.3.7.2, 2.1, 2.5.2, 2.6.2, 2.8.1, 3.2.2, 4.). Add washer to install kit (Table 1-3). Limit APM wire length to 4 inches, clarify APM tests, update lightning categories (2.5.2, 2.8.2, A.1, A.2, Fig C-1). Add exploded-view diagrams (Fig. 2-4, 2-5). Correct MX20 manual refs (4.2.2, 4.3.1.2.2).
-01 --	11/2/04	Extensive updates for GDL 90 Version 2.0 capabilities.
-01 A	11/10/04	Added text for Playaudio command.

ORDERING INFORMATION

To receive additional copies of GDL 90 publications, order the following part numbers:

GDL 90 Installation Manual	560-1049-()
UAT Antenna Installation Guide	560-0215-()
A-33 GPS Antenna Installation Guide	560-0949-()
A-34 GPS Antenna Installation Guide	560-5047-()
GDL 90 Product CD	140-0063-()

List of Effective Pages									
Page	Rev	Page	Rev	Page	Rev	Page	Rev	Page	Rev
Cover	A	2-21	A						
Copyright	A	3-1	A						
i	A	3-2	A						
ii	A	4-1	A						
iii	A	4-2	A						
iv	A	4-3	A						
v	A	4-4	A						
vi	A	4-5	A						
1-1	A	4-6	A						
1-2	A	4-7	A						
1-3	A	4-8	A						
1-4	A	4-9	A						
1-5	A	4-10	A						
1-6	A	4-11	A						
1-7	A	4-12	A						
1-8	A	5-1	A						
1-9	A	5-2	A						
1-10	A	6-1	A						
1-11	A	6-2	A						
1-12	A	A-1	A						
2-1	A	A-2	A						
2-2	A	B-1	A						
2-3	A	B-2	A						
2-4	A	B-3	A						
2-5	A	B-4	A						
2-6	A	C-1	A						
2-7	A	C-2	A						
2-8	A	C-3	A						
2-9	A	C-4	A						
2-10	A	D-1	A						
2-11	A	D-2	A						
2-12	A								
2-13	A								
2-14	A								
2-15	A								
2-16	A								
2-17	A								
2-18	A								
2-19	A								
2-20	A								

TABLE OF CONTENTS

1	GENERAL INFORMATION	1-1
1.1	ABOUT THIS MANUAL.....	1-1
1.1.1	MANUAL ORGANIZATION	1-1
1.1.2	SCOPE.....	1-1
1.2	EQUIPMENT DESCRIPTION	1-2
1.2.1	FEATURES	1-2
1.2.2	SYSTEM INTERFACES.....	1-2
1.3	SPECIFICATIONS	1-5
1.3.1	ELECTRICAL	1-5
1.3.2	PHYSICAL	1-5
1.3.3	ENVIRONMENTAL	1-5
1.3.4	GPS/WAAS RECEIVER PERFORMANCE	1-5
1.3.5	UAT PERFORMANCE	1-6
1.3.6	AVIONICS INTERFACES	1-6
1.3.7	ANTENNA REQUIREMENTS	1-7
1.4	REGULATORY COMPLIANCE	1-9
1.4.1	TSO AND ADVISORY CIRCULAR REFERENCES.....	1-9
1.4.2	TSO AUTHORIZATION	1-9
1.4.3	FCC GRANT OF EQUIPMENT AUTHORIZATION.....	1-9
1.4.4	GDL 90 STC AUTHORIZATION.....	1-10
1.5	UNPACKING THE EQUIPMENT	1-10
1.6	PACKAGE CONTENTS.....	1-10
1.7	DEFINITIONS & ACRONYMS.....	1-11
2	INSTALLATION.....	2-1
2.1	PRE-INSTALLATION INFORMATION	2-1
2.2	INSTALLATION OVERVIEW.....	2-1
2.3	MATERIALS NOT SUPPLIED	2-1
2.3.1	MATERIALS REQUIRED BUT NOT SUPPLIED.....	2-1
2.4	SPECIAL TOOLS REQUIRED.....	2-2
2.5	EQUIPMENT MOUNTING	2-3
2.5.1	CABLING AND WIRING.....	2-3
2.5.2	MOUNTING TRAY INSTALLATION	2-3
2.5.3	UNIT INSERTION & REMOVAL	2-7
2.6	ANTENNA INSTALLATION AND CONNECTIONS	2-7
2.6.1	GPS ANTENNA	2-8
2.6.2	UAT ANTENNAS	2-9
2.7	ELECTRICAL CONNECTIONS	2-10
2.7.1	INTERFACE CONNECTOR DEFINITION.....	2-11
2.8	FUNCTIONAL DESCRIPTIONS.....	2-14
2.8.1	POWER	2-14
2.8.2	MICRO AIRCRAFT PERSONALITY MODULE (APM)	2-14
2.8.3	STATUS LEDs	2-14
2.8.4	DISCRETE OUTPUT	2-15
2.8.5	DISCRETE INPUTS	2-16
2.8.6	SERIAL INTERFACES	2-17
2.8.7	AUDIO	2-18
2.8.8	SUPPRESSION OUTPUT	2-18
2.9	WEIGHT AND BALANCE.....	2-19
2.10	ELECTRICAL LOAD ANALYSIS	2-21
3	LIMITATIONS.....	3-1
3.1	OPERATION	3-1
3.2	INSTALLATION.....	3-1
3.2.1	SURVEILLANCE SERVICES.....	3-1

3.2.2	GPS ANTENNA	3-1
3.2.3	UAT ANTENNA	3-1
3.2.4	ANTENNA INSTALLATION – GENERAL.....	3-2
3.2.5	EQUIPMENT INTERFACED TO THE GDL 90.....	3-2
3.2.6	TRAFFIC DISPLAY	3-2
3.2.7	PRESERVATION OF PREVIOUS SYSTEMS.....	3-2
4	POST INSTALLATION CONFIGURATION & CHECKOUT PROCEDURES.....	4-1
4.1	MOUNTING AND WIRING CHECK	4-1
4.2	EQUIPMENT SETUP AND CONFIGURATION	4-1
4.2.1	MAINTENANCE MODE	4-2
4.2.2	MICRO APM INITIALIZATION PROCEDURE	4-5
4.2.3	MICRO APM CONFIGURATION WORKSHEET	4-9
4.2.4	MX20 SETUP	4-10
4.3	EQUIPMENT OPERATIONAL/FUNCTIONAL TEST	4-10
4.3.1	SYSTEM CHECKOUT – GROUND CHECKS.....	4-10
5	TROUBLESHOOTING	5-1
5.1	TROUBLESHOOTING PROCEDURE	5-1
5.2	COLLECTING ADDITIONAL INFORMATION.....	5-2
5.2.1	MESSAGES FOR SERVICE COMMAND.....	5-2
5.2.2	MESSAGES FOR EXTERNAL COMMAND	5-3
5.3	CONTACTING THE FACTORY FOR ASSISTANCE.....	5-4
6	PERIODIC MAINTENANCE	6-1
6.1	EQUIPMENT CALIBRATION.....	6-1
6.2	CLEANING	6-1
6.3	BATTERY REPLACEMENT	6-1
6.4	ALTITUDE SOURCE.....	6-1
	APPENDIX A - CERTIFICATION DATA.....	A-1
A.1	GDL 90 ENVIRONMENTAL QUALIFICATION - FIXED-WING	A-1
A.2	GDL 90 ENVIRONMENTAL QUALIFICATION - ROTORCRAFT	A-2
A.3	MICRO APM ENVIRONMENTAL QUALIFICATION	A-3
	APPENDIX B - TROUBLESHOOTING FLOWCHARTS.....	B-1
	APPENDIX C - INTERCONNECT DIAGRAMS	C-1
	APPENDIX D - CONSTRUCTION & VALIDATION OF STRUCTURES.....	D-1
LIST OF TABLES		
TABLE 1-1.	TSO AUTHORIZATION	1-9
TABLE 1-2.	PACKAGE CONTENTS.....	1-10
TABLE 1-3.	INSTALLATION KIT CONTENTS (PN 424-6081-100)	1-10
TABLE 1-4.	OPTIONAL PARTS.....	1-10
TABLE 2-1.	CRIMP TOOL FOR P/N 245-0027	2-2
TABLE 2-2.	INTERFACE CONNECTORS.....	2-10
TABLE 2-3.	CRIMP CONTACT SPECIFICATIONS	2-10
TABLE 2-4.	MAIN SYSTEM CONNECTOR PIN-OUT (P1).....	2-12
TABLE 2-5.	I/O CONNECTOR PIN-OUT (P2).....	2-13
TABLE 2-6.	UNIT WEIGHTS	2-19
TABLE 2-7.	UNIT POWER LOADS.....	2-21
TABLE 4-1.	MAINTENANCE MODE COMMANDS.....	4-2
TABLE 4-2.	DATA ITEMS FOR APM INITIALIZATION	4-8
TABLE 4-3.	GDL 90 POST-INSTALLATION CHECKOUT LOG.....	4-13
TABLE 5-1.	TROUBLESHOOTING GUIDE	5-1
TABLE D-1.	STATIC TEST LOAD.....	D-1

LIST OF ILLUSTRATIONS

FIGURE 1-1. SAMPLE GDL 90 SYSTEM DIAGRAM.....	1-3
FIGURE 2-1. SINGLE ENGINE AIRCRAFT GDL 90 MOUNTING LOCATIONS	2-4
FIGURE 2-2. MULTI-ENGINE AIRCRAFT GDL 90 MOUNTING LOCATIONS	2-4
FIGURE 2-3. GDL 90 MOUNTING TRAY & DIMENSIONS	2-5
FIGURE 2-4: GDL 90 TRAY & CONNECTORS	2-6
FIGURE 2-5: GDL 90 TRAY & OPTIONAL COVER	2-7
FIGURE 2-6. ANTENNA PLACEMENT.....	2-8
FIGURE 2-7. RIGHT ANGLE COAX CONNECTOR ASSEMBLY	2-9
FIGURE 2-8. REAR CONNECTOR LAYOUT.....	2-11
FIGURE 2-9. 15-PIN CONNECTOR	2-12
FIGURE 2-10. 37-PIN CONNECTOR.....	2-13
FIGURE 2-11. GDL 90 CENTER OF GRAVITY.....	2-20
FIGURE C-1. INTERCONNECT DIAGRAM FOR INSTALLATION W/ MX20 MFD.....	C-3
FIGURE C-2. INTERCONNECT DIAGRAM FOR INSTALLATION W/ MX20 MFD.....	C-4
FIGURE D-2. UPWARD STATIC LOAD TEST	D-2
FIGURE D-3. FORWARD STATIC LOAD TEST	D-2

NOTES

1 GENERAL INFORMATION

1.1 ABOUT THIS MANUAL

This manual describes the installation and checkout procedures for the GDL 90 UAT Data Link Sensor. It is intended for use by persons certified by the Federal Aviation Administration (FAA) to install avionics devices.

1.1.1 MANUAL ORGANIZATION

SECTION 1	Provides GENERAL INFORMATION about the GDL 90 unit. TSO certification information is also included in this section.
SECTION 2	Includes INSTALLATION procedures.
SECTION 3	Includes LIMITATIONS for the equipment and installation.
SECTION 4	Includes POST-INSTALLATION CONFIGURATION AND CHECKOUT procedures.
SECTION 5	Includes TROUBLESHOOTING information.
SECTION 6	Includes PERIODIC MAINTENANCE requirements.
APPENDIX A	Includes CERTIFICATION DATA .
APPENDIX B	Includes TROUBLESHOOTING FLOWCHARTS .
APPENDIX C	Includes INTERCONNECT DIAGRAMS .
APPENDIX D	Includes CONSTRUCTION & VALIDATION of structures.

1.1.2 SCOPE

The information in this manual is STC approved. Only the equipment interfaces covered in this manual are within the scope of this STC. Other equipment may be suitable for use with the GDL 90, but use of such equipment is beyond the scope of this STC – additional FAA approval may be required if equipment not covered in this manual is used to interface to the GDL 90.

This document describes the GDL 90 operating with software Version 2.0 and later. Version 2.0 is backward-compatible with previous versions of GDL 90 software.

Antenna installation in the pressure vessel of pressurized aircraft is also beyond the scope of the GDL 90 STC. Additional manufacturer's data may be necessary and FAA approval may be required to cover the installation of the antenna.

Refer to Section 3 Limitations for additional information.

1.2 EQUIPMENT DESCRIPTION

The Garmin GDL 90 is a remote-mounted product that contains a GPS/WAAS engine and a Universal Access Transceiver. The GDL 90 will transmit ownship data via the UAT data link. It will receive data from other UAT-equipped aircraft, as well as FIS-B weather – the received data may be output to an appropriate display.

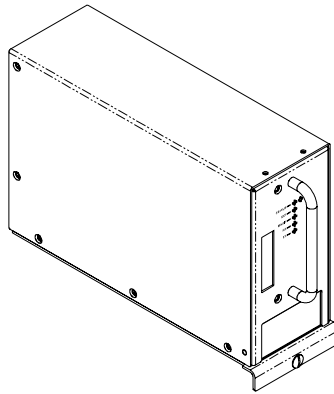

1.2.1 FEATURES

The features of the GDL 90 UAT Data Link Sensor include:

- 10-40 VDC Power Capability
- 978 MHz Universal Access Transceiver data link radio designed to support ADS-B, TIS-B and FIS-B airborne and ground applications
- GPS/WAAS engine for state-of-the-art fast, accurate navigation (15-channel, 3 WAAS decoders, 5 Hz update of position, time, and velocity)
- Interface to Altitude Encoder via RS232 bus
- Interface to a Control Panel or Transponder via RS232 bus
- Interface to Garmin MX20 Multi-function Display or other display units

1.2.2 SYSTEM INTERFACES

The interfaces for a typical GDL 90 are shown in Figure 1-1. The available interfaces are further described in the following sections.

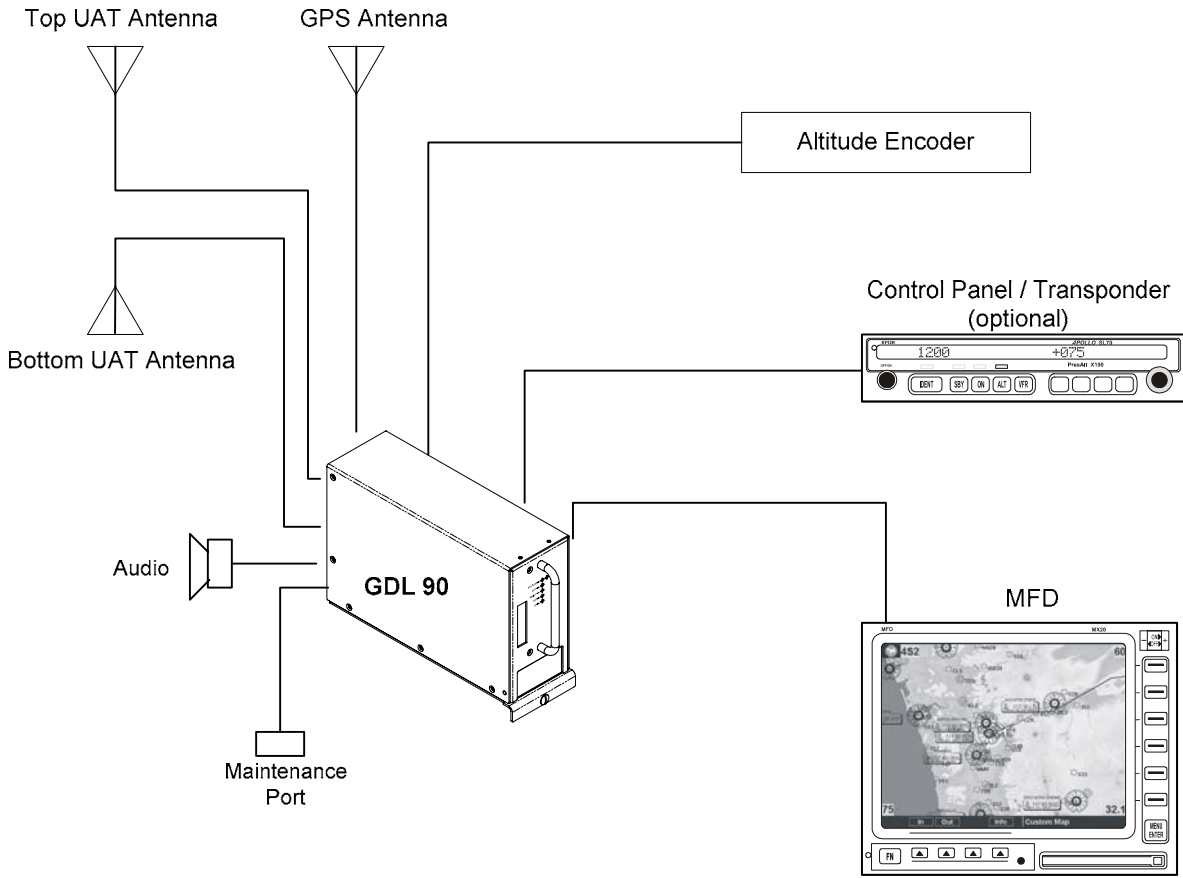

Figure 1-1. Sample GDL 90 System Diagram

1.2.2.1 Multi-Function Display

The GDL 90 is capable of driving one display with traffic and weather information. If the display is an MX20, it must use software Version 5.3 or later.

1.2.2.2 Altitude Encoder

The GDL 90 is capable of interfacing to an altitude encoder to obtain altitude data via a RS232 bus.

1.2.2.3 Control Panel

The GDL 90 is capable of interfacing to an optional Control Panel unit or certain models of transponder via a RS232 bus.

1.2.2.4 Annunciator Outputs and Switch Inputs

The GDL 90 can drive one external annunciator lamp and receive inputs from various switches to control its operation.

1.2.2.5 Maintenance Interface

The GDL 90 has a RS232 communication port that is used to configure and check status of the GDL 90 system. Refer to other sections of this manual for more description.

1.2.2.6 Audio Alert

The GDL 90 has one 500 Ω audio output that can be connected to an audio panel to provide audible messages to the pilot.

1.3 SPECIFICATIONS

This section includes detailed electrical, physical, environmental and performance specifications for the GDL 90.

1.3.1 ELECTRICAL

Input voltage	10 - 40 VDC
Input current (typical)	1.5 A at 14 VDC 750 mA at 28 VDC

1.3.2 PHYSICAL

Height.....	7.42 inches (18.84 cm)
Width	3.54 inches (8.97 cm)
Depth.....	12.64 inches (32.11 cm)
Weight.....	6.4 lb (2.9 kg) with mounting tray 1.2 lb (0.54 kg) mounting tray only

1.3.3 ENVIRONMENTAL

The GDL 90 is designed and tested to meet appropriate categories as shown in the Environmental Qualification Form included in Appendix A.

Operating temperature	-20°C to +55°C
Storage temperature	-55°C to +85°C
Temperature variation.....	5°C per minute
Humidity	95% at 65°C
Maximum continuous altitude	55,000 feet
Decompression.....	55,000 feet
External Cooling.....	Not required with internal fans operational and vents unobstructed
Water-resistant.....	with vertical mounting and optional cover

1.3.4 GPS/WAAS RECEIVER PERFORMANCE

TSO Compliance.....	TSO-C145a (RTCA/DO-229C)
Number of channels.....	15 (12 GPS and 3 GPS/WAAS/SBAS)
Frequency.....	1575.42 MHz L1, C/A code
Sensitivity (acquisition).....	-116 dBm to -134.5 dBm GPS -116 dBm to -135.5 dBm WAAS
Sensitivity (drop lock)	-144 dBm
Dynamic range	> 20 dB
Lat/Long position accuracy	<1 meter RMS typical with WAAS (horizontal/vertical)
Velocity.....	1000 knots maximum (above 60,000 ft)

TTFF (time to first fix)	1:45 min. typical with current almanac, position, and time
Reacquisition	10 seconds typical
Position update interval	0.2 sec (5 Hz)
1 pps (pulse per second)	±275 nsec of UTC second
Datum.....	WGS-84
SATCOM compatibility	Compatible on aircraft equipped with SATCOM
Antenna power supply	35 mA typical, 40 mA max at 4.7 VDC

1.3.5 UAT PERFORMANCE

TSO Compliance.....	TSO-C154 (RTCA/DO-282)
Frequency.....	978.00 MHz
Transmit Power.....	50 W (+47 dBm)
Frequency Tolerance	+/- 20 PPM
Modulation.....	Continuous Phase FSK, h = 0.6, Raised Cosine shaping, a = 0.5
Data Rate	1.04 Mbps
99% Power Bandwidth	1.3 MHz
60 dB bandwidth.....	3.3 MHz (estimated)
Receiver Sensitivity	-96 dBm for 90% MSR

1.3.6 AVIONICS INTERFACES

Annunciator Outputs.....	Open collector output capable of sinking up to 400 mA for turning ON annunciator lamp
Display	RS-422 asynchronous serial
Altitude Encoder	RS-232 asynchronous serial
Control Panel	RS-232 asynchronous serial

1.3.7 ANTENNA REQUIREMENTS

1.3.7.1 GPS Antennas

1.3.7.1.1 A-33 (590-1104)

Early production runs of PN 590-1104 were marked with TSO-C129a. This antenna was re-qualified to TSO-C144 with no changes to the antenna. P/N 590-1104 antennas marked with TSO-C129a identification are identical to those marked with TSO-C144.

Applicable TSO: TSO-C144 (RTCA/DO-228 with Change No. 1)

Frequency: 1575 MHz

Polarization: Right Hand Circular

Axial Ratio: 3 dB Max at bore site

Radiation Coverage:	Elevation Angle	Minimum Gain
	>15°	-2.0 dBic
	10°	-3.0 dBic
	5°	-4.5 dBic
	0°	-7.5 dBic

Finish: Polyurethane Enamel

Weight: 3.9 oz. (0.11 kg)

Height: 0.61 inches (1.55 cm)

Operating Temperature: -55°C to +85°C

Operating Altitude: 55,000 feet (16,764m) max.

Amplifier:

Gain 26.5 dB ±2 dB

Noise Figure: 2.5 dB Max

Impedance: 50 ohms

VSWR (Dry): ≤ 1.5:1

VSWR (Rain): ≤ 2.0:1

Band Rejection: 35 dB

Power Handling: 1 Watt

Voltage: 5 VDC ±10%

Current: 35 mA nominal, 40 mA max.

L1 Filter Bandwidth..... 1575 ±20 MHz (3 dB)
+110, -210 MHz (60dB)

Group Delay (3dB bandwidth)..... 27 ±10 nanosecond

Pass Band Ripple (3dB bandwidth)0.2 dB max

1.3.7.1.2 A-34 (590-1112)

Early production runs of PN 590-1112 were marked with TSO-C129a. This antenna was re-qualified to TSO-C144 with no changes to the antenna. P/N 590-1112 antennas marked with TSO-C129a identification are identical to those marked with TSO-C144.

Applicable TSO: TSO-C144 (RTCA/DO-228 with Change No. 1)

Frequency: 1575 MHz

Polarization: Right Hand Circular

Axial Ratio: 3 dB Max at bore site

Radiation Coverage:	Elevation Angle	Minimum Gain
	>15°	-2.0 dBic
	10°	-3.0 dBic
	5°	-4.5 dBic
	0°	-7.5 dBic

Finish: Polyurethane Enamel

Weight: 7.0 oz. (0.2 kg)

Height: 0.66 inches (1.76 cm)

Operating Temperature: -55°C to +85°C

Operating Altitude: 55,000 feet (16,764m) max.

Amplifier:

Gain 26.5 dB ±2 dB

Noise Figure: 2.5 dB Max

Impedance: 50 ohms

VSWR (Dry): ≤ 1.5:1

VSWR (Rain): ≤ 2.0:1

Band Rejection: 35 dB

Power Handling: 1 Watt

Voltage: 5 VDC ±10%

Current: 35 mA nominal, 40 mA max.

L1 Filter Bandwidth 1575 ±20 MHz (3 dB)
+110, -210 MHz (60dB)

Group Delay (3dB bandwidth) 27 ±10 nanosecond

Pass Band Ripple (3dB bandwidth) 0.2 dB max

1.3.7.2 UAT Antenna

The GDL 90 requires a UHF antenna meeting the following specifications:

- Standard 50Ω vertically polarized antenna with a VSWR < 1.7:1 at 978 Mhz
- TSO-C66, C74, C112 or C154 antennas that also meet the VSWR specification.

NOTE

Certain types of transponder antennas that utilize very thin radiator elements are only intended for use at 1030 and 1090 MHz. These types of antennas should be evaluated on a model-by-model basis to determine their suitability as UAT data link antennas.

CAUTION

Operating the GDL 90 with no RF terminations on the Top or Bottom UAT Antenna ports can result in equipment damage. Always operate the GDL 90 with the Top and Bottom UAT Antenna ports terminated with a VSWR ratio of 3.0:1 or less.

1.4 REGULATORY COMPLIANCE

1.4.1 TSO AND ADVISORY CIRCULAR REFERENCES

- TSO-C154 Universal Access Transceiver (UAT) Automatic Dependent Surveillance – Broadcast (ADS-B) Equipment Operating on the Frequency of 978 MHz.
- TSO-C145A Airborne Navigation Sensors using GPS Augmented by WAAS

NOTE

Unauthorized changes or modifications to the GDL 90 may void the compliance to required regulations and authorization for continued equipment usage.

1.4.2 TSO AUTHORIZATION

Table 1-1. TSO Authorization

Function	TSO	Minimum Performance Standard	Software RTCA/DO-178B
UAT Transceiver	TSO-C154, Class A1H, B1	RTCA/DO-282	Level B,C
GPS/WAAS	TSO-C145A, Class 1	RTCA/DO-229C, Class 1	Level B

1.4.3 FCC GRANT OF EQUIPMENT AUTHORIZATION

- The GDL 90 has been issued an FCC Grant of Equipment Authorization. The FCC ID is marked on the equipment nameplate.

1.4.4 GDL 90 STC AUTHORIZATION

Refer to the GDL 90 Product CD 140-0063-xx for data regarding GDL 90 STC authorization.

1.5 UNPACKING THE EQUIPMENT

Carefully unpack the equipment. Visually inspect the package contents for any evidence of shipping damage. Retain all shipping containers and packaging material in case reshipment is necessary.

1.6 PACKAGE CONTENTS

As shipped from the Garmin AT factory, the GDL 90 package includes most necessary items for installation other than supplies normally available at the installation shop, such as wire and cable ties, circuit breakers, and required input and output equipment. The items included in the package are listed in Table 1-2 and Table 1-3. In addition, Table 1-4 lists optional parts that may be needed for non-standard installations.

Table 1-2. Package Contents

Part #	Qty	Description
424-6081-1xx	1	GDL 90 Installation Kit (see Table 1-3 for detail)
430-6081-1xx-xxx	1	GDL 90 UAT Data Link Sensor
140-0063-xx	1	GDL 90 Product CD
590-1104	1	A33 GPS Antenna
590-0051 OR	2	UAT Blade Antenna, passive, TNC
590-0052		

Table 1-3. Installation Kit Contents (PN 424-6081-100)

Part #	Qty	Description
162-0043	3	Connector, coax, RA, PNL MNT
265-0007	3	Retainer Ring, ext,7/16 shaft
240-0008	3	Washer, 0.446 ID 0.56 OD
162-1574	1	Receptacle DSUB 9-pin
162-1575	1	Receptacle DSUB 15-pin
162-1577	1	Receptacle DSUB 37-pin
162-2080	3	Connector, coax, RA, plug clamp, TNC
202-0002	8	Cable tie
224-0404	4	Screw, 4-40 x 1/4 SS flat head Phillips 82 deg.
245-0027	25	Crimp contact, DSUB, 20 to 24 AWG wire
310-0461-00	1	Cover Mounting Tray GDL 90
310-0462-00	1	Mounting Tray GDL 90
430-6200-000	1	Aircraft Personality Module (APM)
660-0014	50	Cable, coax RG400 dbl shld 50-ohm (feet)

Table 1-4. Optional Parts

Part #	Description
310-0467-xx	Capstone Phase 1 Adapter Plate
500-0290-xx	Capstone Phase 1 Adapter Cable
560-1057-xx	GDL 90 Capstone Upgrade Instructions

1.7 DEFINITIONS & ACRONYMS

ADC	Air Data Computer
ADS-B	Automatic Dependant Surveillance - Broadcast
AHRS	Attitude Heading Reference System
ALT	Altitude
APM	Aircraft Personality Module
EN	Engineering Notice
GPS	Global Positioning System
MFD	Multi-Function Display
STC	Supplementary Type Certificate
TSO	Technical Standard Order
UAT	Universal Access Transceiver
WAAS	Wide Area Augmentation System

NOTES

2 INSTALLATION

This section describes the installation of the GDL 90 including mounting, wiring, and connections. Post-Installation configuration and checkout procedures are included in Section 3.

2.1 PRE-INSTALLATION INFORMATION

Always follow acceptable avionics installation practices per FAA Advisory Circulars (AC) 43.13-1B, 43.13-2A, or later FAA approved revisions of these documents.

Follow the installation procedure in this section as it is presented for a successful installation. Read the entire section before beginning the procedure. Prior to installation, consider the structural integrity of the GDL 90 installation as defined in AC 43.13-2A, Chapter 1. Perform the post installation checkout before closing the work area in case problems occur.

Complete an electrical load analysis in accordance with AC 43.13-1B, Chapter 11, on the aircraft prior to starting modification to ensure aircraft has the ability to carry the GDL 90 load. Refer to Section 2.10 for the power consumption of each GDL 90 mode of operation. Document the results of the electrical load analysis on FAA Form 337.

The WAAS/GPS installation instructions have been prepared to meet the guidance material defined in AC20-138A Airworthiness Approval of Global Navigation Satellite System (GNSS) Equipment.

CAUTION

Operating the GDL 90 with no RF terminations on the Top or Bottom UAT Antenna ports can result in equipment damage. Always operate the GDL 90 with the Top and Bottom UAT Antenna ports terminated with a VSWR ratio of 3.0:1 or less.

2.2 INSTALLATION OVERVIEW

A successful installation should start with careful planning, including determination of mounting location for the GDL 90, cable routing, and other required modifications. Once the mounting location has been determined, prepare the mounting tray for installation. It may be easier to complete the wiring harness and attach the connectors to the tray upon installation.

2.3 MATERIALS NOT SUPPLIED

2.3.1 MATERIALS REQUIRED BUT NOT SUPPLIED

The GDL 90 is intended for use with standard aviation accessories. The following items are required for the installation, but not supplied:

- Wire (MIL-W-22759/16 or equivalent)
- Shielded wire (MIL-C-27500 or equivalent)
- Circuit breakers
- Ring terminals (for grounding)

2.4 SPECIAL TOOLS REQUIRED

Some of the connectors use crimp contacts. The tables below identify crimp tools required to ensure consistent, reliable crimp contact connections for the rear D-sub connectors. The tables define one source for the crimp tool. Alternate equivalent tools may be used.

Table 2-1. Crimp Tool for P/N 245-0027

Description	ITT/Cannon P/N	Military number
Insertion/Extraction tool CIET-20HD	980-200-426	M81969/39-01
Crimp tool	995-0001-584	M22520/2-01
Positioner	995-0001-604	M22520/2-08

Below is the contact for ITT/Cannon crimp tools:
ITT Cannon Phone (714) 261-5300
1851 E. Deere Ave FAX (714) 575-8324
Santa Ana, CA 92705-6500

Install the retainer ring for the coaxial connectors using external snap ring pliers, Diamond D32R or equivalent. Note that the access holes inside the tray are enlarged and offset to provide access for the pliers.

2.5 EQUIPMENT MOUNTING

2.5.1 CABLING AND WIRING

Wiring should be installed in accordance with AC 43.13-1B Chapter 11. When wire separation cannot be achieved, the following issues should be addressed:

- The cable harness should not be located near flight control cables and controls, high electrical capacity lines or fuel lines
- The cable harness should be located in a protected area of the aircraft
- Do not route cable near high-energy sources

Refer to the interconnection diagrams in Appendix C for the appropriate wiring. Once the cable assemblies have been made, attach the cable connectors to the rear of the mounting tray. Route the wiring bundle as appropriate. Use 22 to 24 AWG wire for all connections except for power. Use 20 AWG for power/ground. Avoid sharp bends.

2.5.2 MOUNTING TRAY INSTALLATION

The GDL 90 does not require forced-air cooling; however, when mounting the GDL 90, avoid locating the GDL 90 near sources that produce high levels of heat. The tray can be installed in a variety of locations, such as the electronics bay, under a seat or behind the rear baggage area. Refer to Figure 2-1 and Figure 2-2 for suggested location. Leave sufficient clearance between the GDL 90 and any obstruction. Install tray in accordance with AC 43.13-2A Chapter 2 Radio Installations. Tray should be mounted to a surface known to have sufficient structural integrity to withstand additional inertia forces imposed by a 6.4-pound unit. If it is necessary to build a shelf or bracket to mount the GDL 90 tray or it is not certain that the chosen location is of sufficient structural integrity, refer to Appendix D.

Refer to Figure 2-3 for the GDL 90 tray dimensions. The tray can be mounted vertically using four 8-32 pan head screws (MS35206, AN526 or equivalent.) It can also be mounted horizontally using four 6-32 100° counter-sunk flathead screws (MS24693, AN507R or equivalent.) For installation in rotorcraft, the tray must be mounted vertically.

Install tray in accordance with AC 43.13-2A Chapter 2 Radio Installations. Ensure that the GDL 90 chassis has a ground path to the airframe by having at least one mounting screw in contact with the airframe. If more water-resistance is desired, tray should be installed in the upright vertical orientation only.

After the cable assemblies are made and wiring installed to the mounting tray back plate, route wiring bundle as appropriate. Use cable ties to secure the cable assemblies and coax to the holes provided in the side of the connector plate to provide strain relief for the cable assemblies. The cable shields should be grounded directly to a lug mounted to one of the holes on the side of the connector plate, keeping the ground leads to a maximum of 3 inches long.

Prepare the APM wires by stripping the leads and crimping the contacts. The APM wire length must be 4 inches maximum.

The APM may be fastened to the back of the tray next the 37-pin connector using cable ties through any of the four holes provided in the backplate. Refer to Figure 2-4.

Insert the APM leads into the correct locations on connector P1.

Optional cover is provided for installations that need extra moisture protection. Install cover to aft side of tray using 4 screws that are part of the mounting tray. Refer to Figure 2-5.

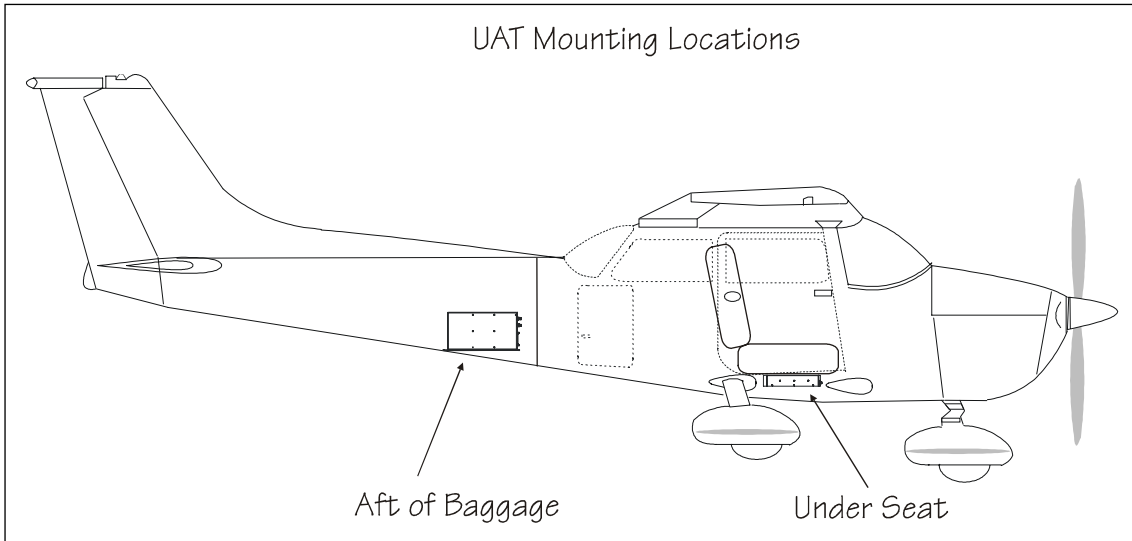

Figure 2-1. Single Engine Aircraft GDL 90 Mounting Locations

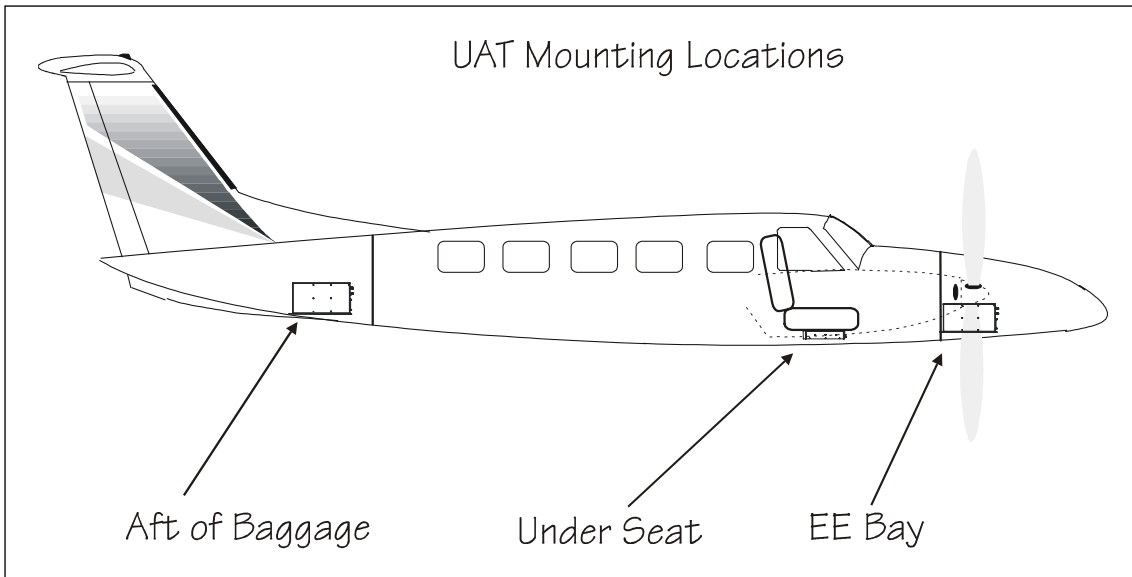
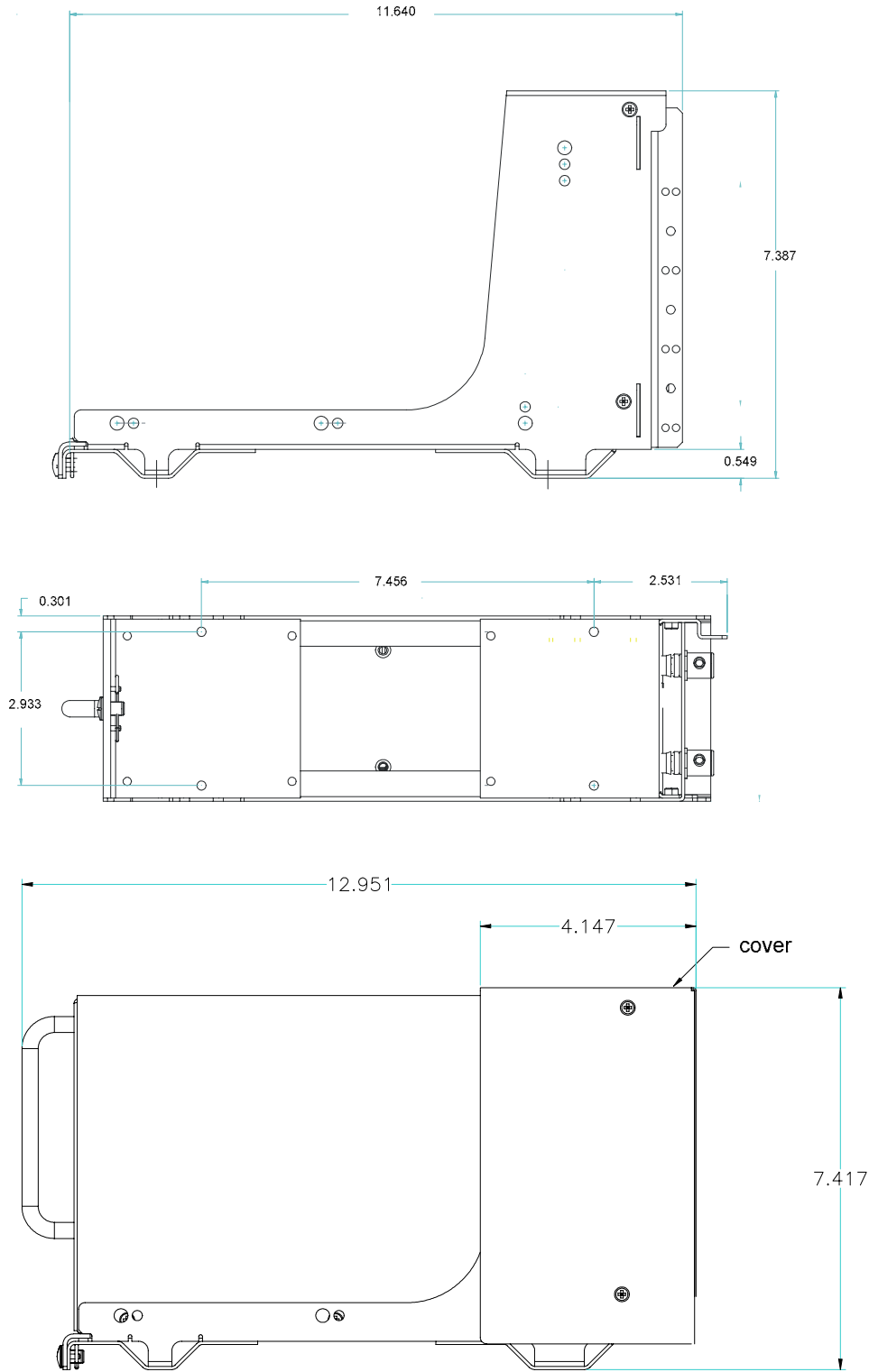

Figure 2-2. Multi-Engine Aircraft GDL 90 Mounting Locations



GDL 90 in tray with optional cover

Figure 2-3. GDL 90 Mounting Tray & Dimensions

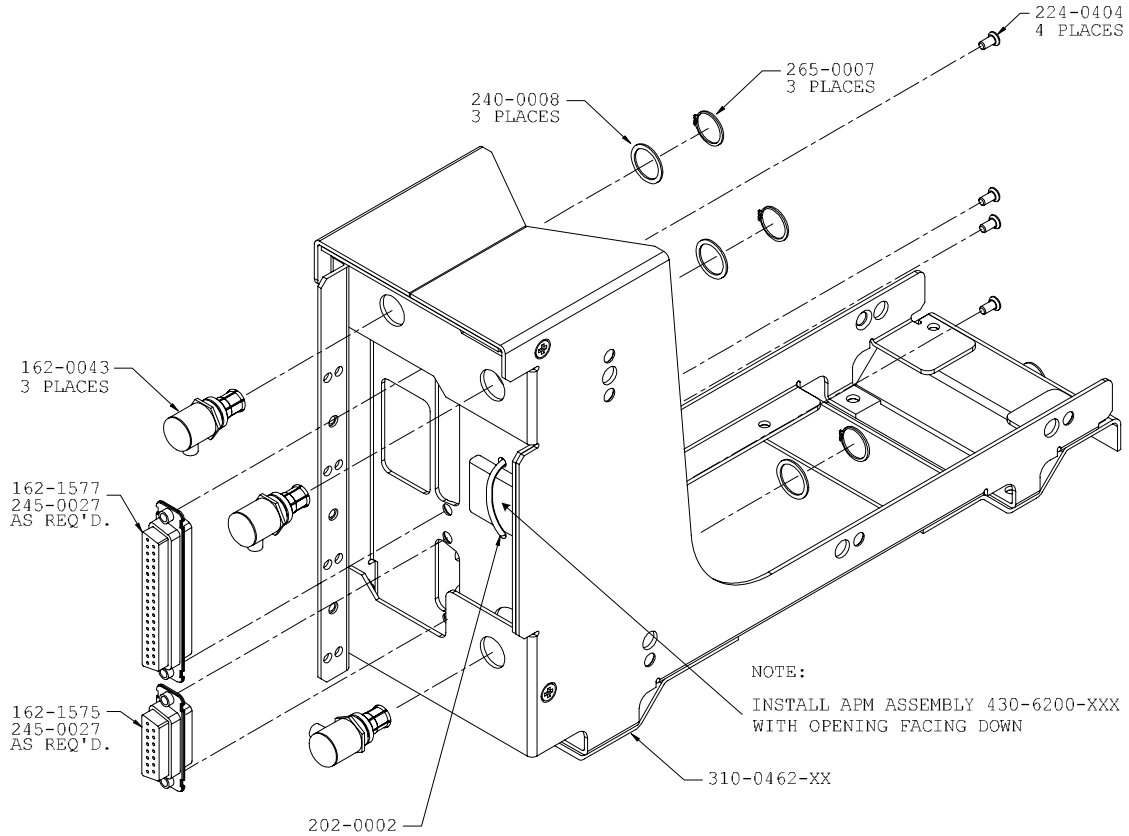

Figure 2-4: GDL 90 Tray & Connectors

CAUTION

Operating the GDL 90 with no RF terminations on the Top or Bottom UAT Antenna ports can result in equipment damage. Always operate the GDL 90 with the Top and Bottom UAT Antenna ports terminated with a VSWR ratio of 3.0:1 or less.

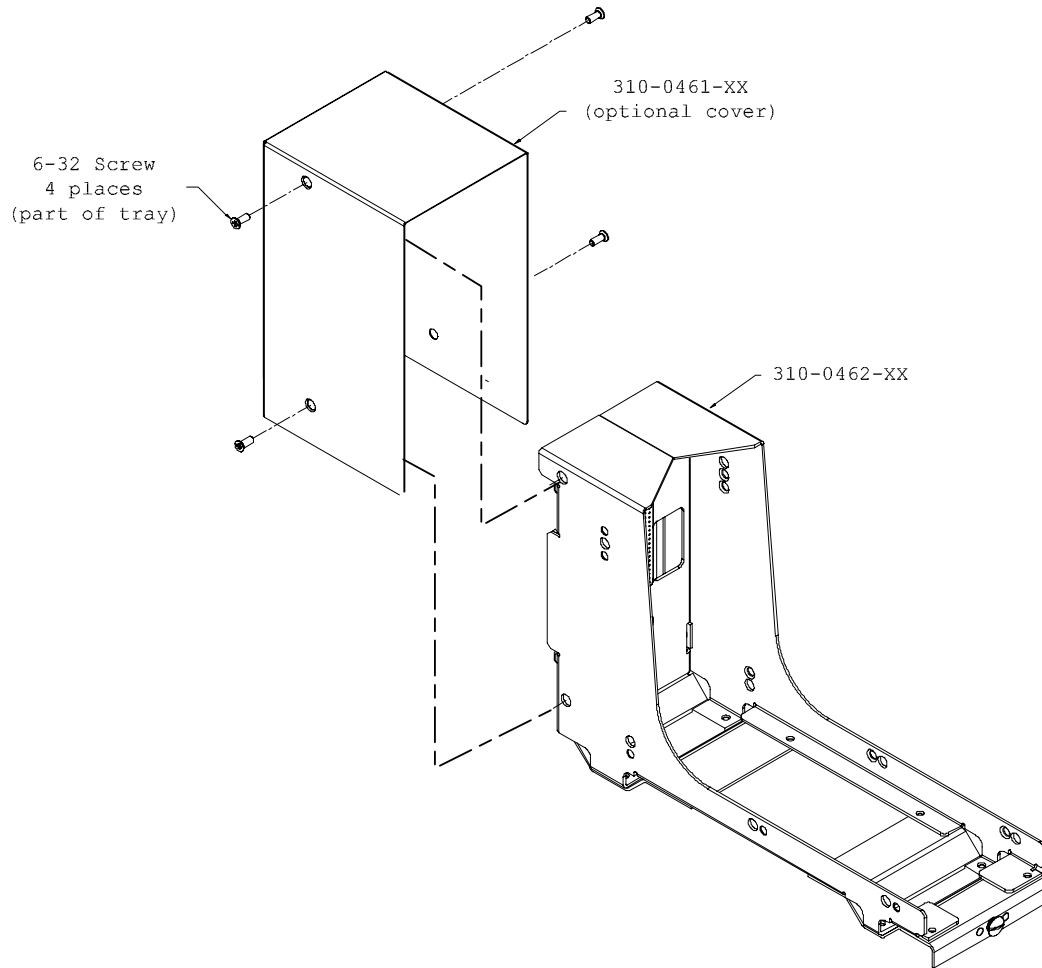

Figure 2-5: GDL 90 Tray & Optional Cover

2.5.3 UNIT INSERTION & REMOVAL

Position the GDL 90 in the mounting tray and slide the unit fully into the tray. Turn the DZUS fastener on the front bottom of the GDL 90 clockwise $\frac{1}{4}$ turn to lock in the unit. If the DZUS fastener is hard to turn or the unit does not seat fully, the unit is probably binding. Check the position of the unit in the mounting tray.

To remove the unit from the mounting tray, turn the DZUS fastener counter-clockwise $\frac{1}{4}$ turn then pull the unit from the tray. No special extraction tools are required.

2.6 ANTENNA INSTALLATION AND CONNECTIONS

The GDL 90 requires three antennas (GPS antenna and two UAT antennas) for Class A1 and B1. Single-UAT-antenna installation is allowed if the aircraft meets all flight test requirements over all normal maneuvers. Garmin AT strongly recommends two UAT antennas be used for all installations. Follow the antenna manufacturer's installation instructions for mounting the antennas.

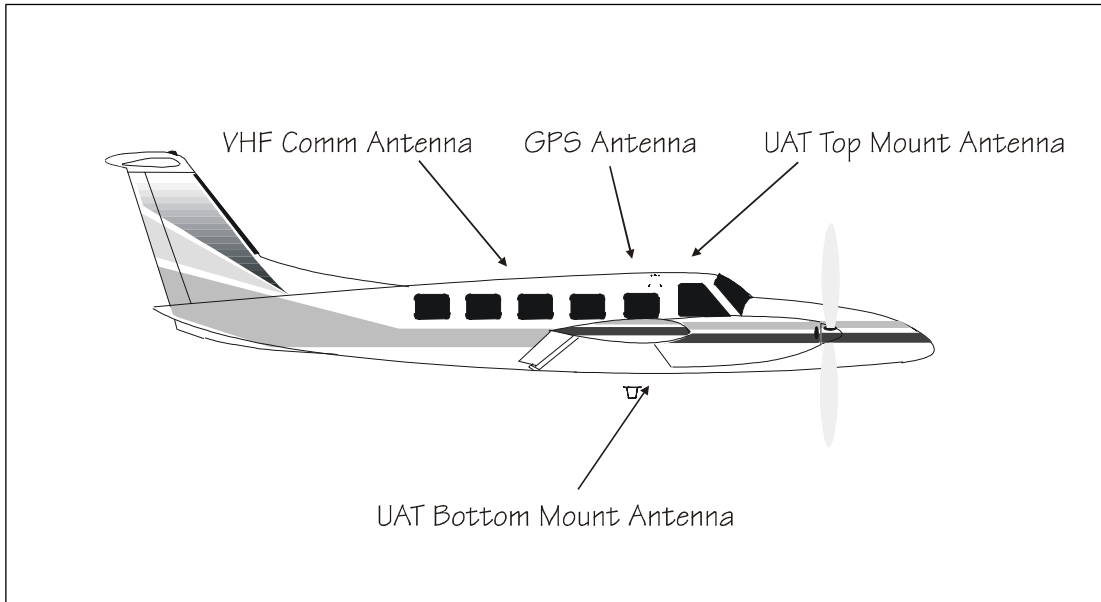

Figure 2-6. Antenna Placement

2.6.1 GPS ANTENNA

The mounting location and cable connections for the GPS antenna are very important. The antenna should be mounted no closer than two feet from VHF comm transmitter antennas, six inches from other antennas emitting less than 25 watts, and two feet from higher power antennas. See A-33 GPS Antenna Installation Manual, p/n 560-0949-xx for more information. Special care should be taken to ensure that the GPS antenna is not mounted in close proximity to antennas that may emit harmonic interference at the L1 frequency of 1575.42 MHz. Refer to AC 20-138A Airworthiness Approval of Global Navigation Satellite System (GNSS) Equipment for additional information and guidelines.

The connectors and RG-400 coax cable are included in the installation kit. Assembly instructions for the connectors are included in Figure 2-7. RG-400 cable up to 35 feet long can be used so long as the cable loss requirements are met. For longer lengths, use low-loss 50Ω coax.

Suggestion: *Temporarily locate the GPS antenna with coax connected to the GDL 90 and check the GPS performance as described in the GPS Nav Checkout in the Equipment Operational/Functional Test Section. Once a suitable location has been verified, permanently mount the antenna.*

NOTE

If using a GPS antenna that was already on the aircraft, or if mounting the antenna closer than recommended distance from a comm antenna, conduct the *GPS Nav Checkout* test in the *Equipment Operational/Functional Test*. If the GDL 90 passes the test, then further measures are not necessary.

Once the antenna mounting position has been prepared, route the coax cable from the antenna to the GDL 90. Proper selection of coax cable and assembly of connectors is critical to GPS signal performance. The cable loss from the GPS antenna shall not be greater than 7 dB. If SatCom is installed on the aircraft, the cable loss shall be 3 dB minimum to ensure proper interference rejection from SatCom. The coaxial connectors and adapters, such as TNC to BNC and GPS splitter, add additional loss to the cable and

should be considered when computing the cable loss. A typical loss of -0.2 dB can be used for each connection. The typical cable loss for 20 feet of RG-400 coax with a connector one each end is 4 dB.

During the post-installation checkout, susceptibility to harmonics of VHF comm. transmitters will be evaluated. If problems arise, then better isolation, or distance, may be required between the GPS and comm antennas, or a 1575.42 MHz notch filter may be installed in series with the antenna coax of the VHF comm transceiver to reduce or eliminate the harmonic interference. A notch filter (part #162-1059) is available from Garmin AT.

If a VHF comm transmitter causes problems with the GPS on the selected frequencies as listed in the post-installation checkout, the problem may be due to the ELT. This can be verified by disconnecting the ELT antenna coax at the ELT unit. If the ELT is found to cause the problem, then contact the ELT manufacturer or replace the ELT.

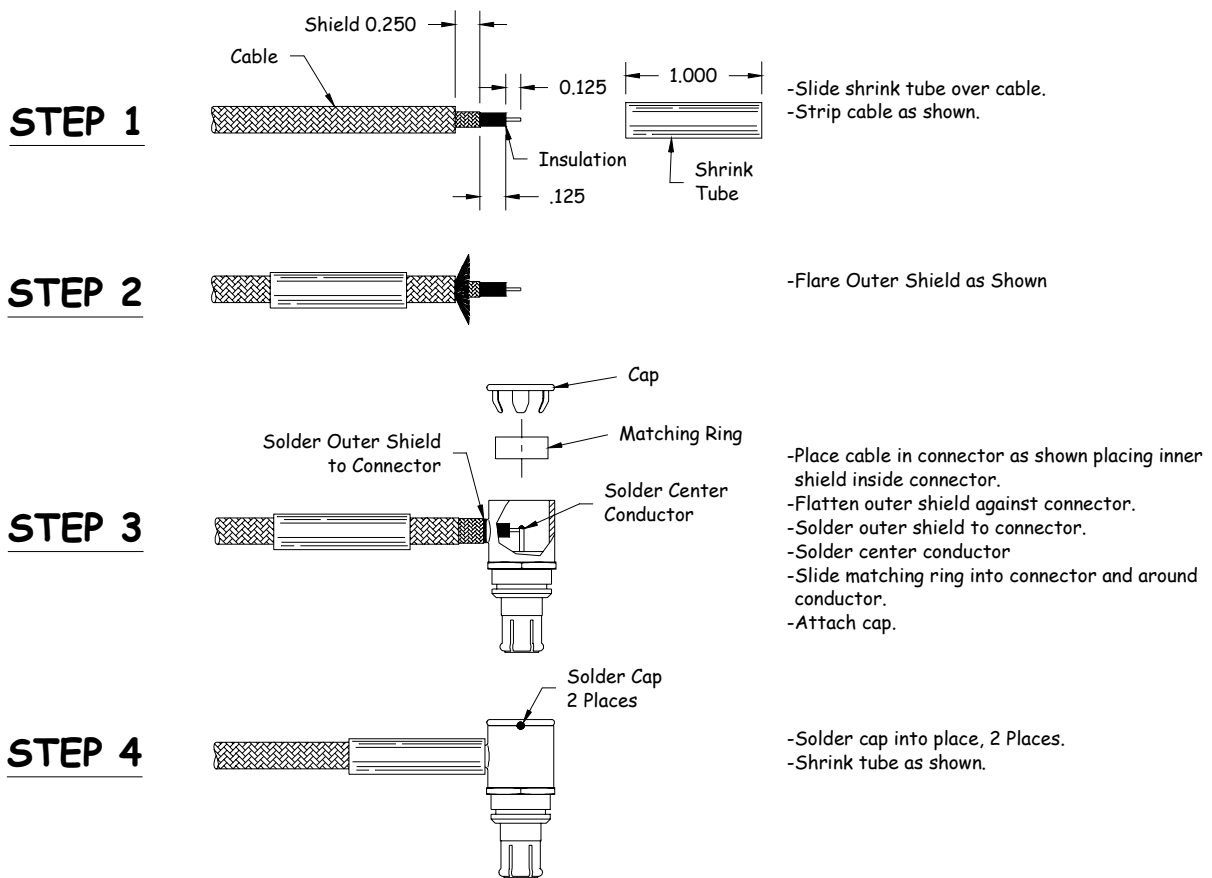

Figure 2-7. Right Angle Coax Connector Assembly

2.6.2 UAT ANTENNAS

The UAT antenna is a standard 50Ω vertically polarized L-band antenna that operates at 978 MHz. Any antenna meeting the requirements of TSO-C66, C74, C112 or C154 and presenting a VSWR of less than 1.7:1 at 978 Mhz is acceptable. Follow the antenna manufacturer’s installation instructions for mounting antennas. Garmin AT P/N 590-0051 or P/N 590-0052 antenna meet these requirements.

The Garmin AT UAT antenna is vertical polarized, optimized for UHF operation, and designed for installation in aircraft, including helicopters. The GDL 90 will receive signals from two antennas on top and bottom of the fuselage. Since UAT is a line-of-sight system, the antenna must have an unobstructed view of the target. Any “shadowing” or signal shading from the aircraft will degrade the performance. Shadowing may be from vertical stabilizers, wings, other antennas, engines, propellers, or the fuselage itself. Proper antenna location and installation is very important for the reception of the signals. See the UAT Antenna Installation Instructions, P/N 560-0215, for complete details.

CAUTION

Operating the GDL 90 with no RF terminations on the Top or Bottom UAT Antenna ports can result in equipment damage. Always operate the GDL 90 with the Top and Bottom UAT Antenna ports terminated with a VSWR ratio of 3.0:1 or less.

2.7 ELECTRICAL CONNECTIONS

The GDL 90 installation kit includes three D-sub connectors and three coax connectors. The connector layouts are shown in Figure 2-8. The D-sub connectors use the supplied crimp contacts as specified in Table 2-2. Make the crimp connections with the crimp tool specified.

Table 2-2. Interface Connectors

Ref.	Description	Connector		Crimp Contact	
		P/N	Description	P/N	Description
P1	I/O	162-1575	15 Pin D-Sub Receptacle	245-0027	20-24 AWG socket contact
P2	I/O	162-1577	37 Pin D-Sub Receptacle	245-0027	20-24 AWG socket contact
n/a	Maint. Port	162-1574	9 Pin D-Sub Receptacle	245-0027	20-24 AWG socket contact
P3	GPS antenna	162-0043	Coax connector, right angle	N/A	N/A
P4	UAT ant (top)	162-0043	Coax connector, right angle	N/A	N/A
P5	UAT ant (bot)	162-0043	Coax connector, right angle	N/A	N/A

The following table shows the specifications for the crimp contacts. Alternate crimp contact part numbers may be used that are equivalent to those specified in the table below.

Table 2-3. Crimp Contact Specifications

Garmin AT Part Number	245-0027
Description	20-24 AWG crimp socket contact
Color bands	Orange/Blue/Gray
ITT/Cannon P/N	031-1007-042
Military number	M39029/63-368

2.7.1 INTERFACE CONNECTOR DEFINITION

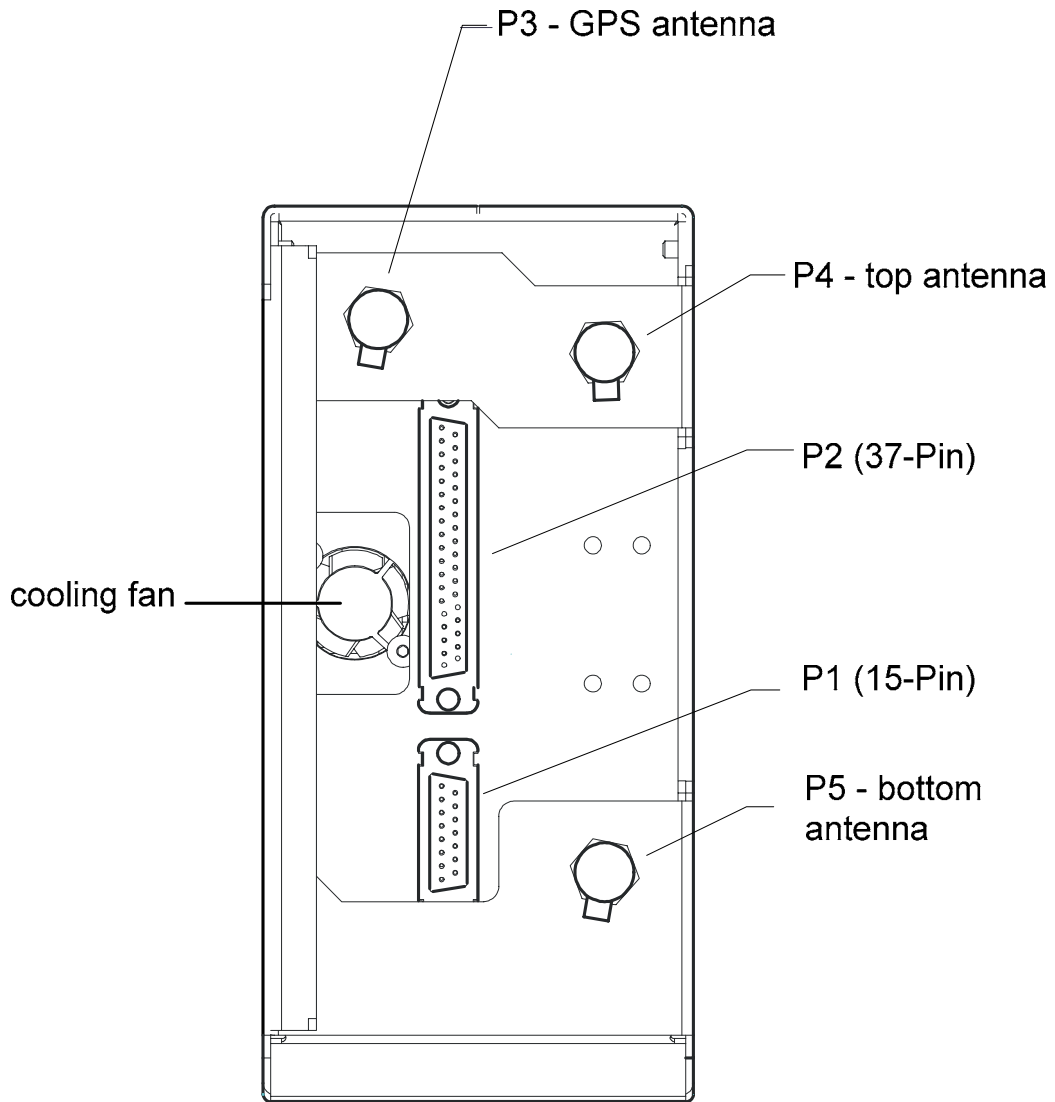
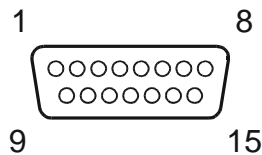

Figure 2-8. Rear Connector Layout

2.7.1.1 Main System Connector (P1)

The basic GDL 90 interface is handled via a standard density male 15-pin D-SUB connector located at the rear of the unit. The pinout for the connector is defined in the following table.

Pin #	I/O	Name	Description
1	I	Power +	Main Aircraft Power Input (+10 to +40 VDC)
2	--	Power Ground	Main Aircraft Power Ground
3	I	Maint RxD	Maintenance Port Serial Data Input
4	O	Maint TxD	Maintenance Port Serial Data Output
5	--	Control Panel Ground	Control Panel Serial Ground
6	O	APM TxD	APM Serial Data Output
7	I	APM RxD	APM Serial Data Input
8	--	RESERVED	RESERVED
9	I	Power +	Main Aircraft Power Input (+10 to +40 VDC)
10	--	Power Ground	Main Aircraft Power Ground
11	--	Maint Serial Ground	Maintenance Port Serial Ground
12	I	Control Panel RxD	Control Panel Serial Data Input
13	O	Control Panel TxD	Control Panel Serial Data Output
14	O	APM Ground	APM Serial Ground
15	--	RESERVED	RESERVED



View looking at rear of unit

Figure 2-9. 15-Pin Connector

2.7.1.2 I/O Connector (P2)

The interface to external equipment is made through a standard male 37-pin D-sub connector near on the rear of the unit. The pin-out for the connector is defined in the following table.

Table 2-5. I/O Connector Pin-Out (P2)			
Pin #	I/O	Name	Description
1	O	Audio Out Hi	Low-Level Audio Out (to audio panel)
2	--	RESERVED	RESERVED
3	--	RESERVED	RESERVED
4	I	TCAS RA Active In	TCAS Resolution Advisory Active Discrete In (active low)
5	I	Audio Inhibit Input	Inhibit Audio Alerts (active low)
6	--	RESERVED	RESERVED
7	--	Serial Ground 7	RS232 signal ground
8	I	Time Mark In +	GPS 1 Pulse Per Second Input + (RS422 Level)
9	O	Time Mark Out +	GPS 1 Pulse Per Second Output + (RS422 Level)
10	I	RS422 Rx D3 +	RS422 channel 3 serial data input +
11	O	RS422 Tx D3 +	RS422 channel 3 serial data output +
12	I	429 IN 4A	ARINC 429 In Channel 4A
13	I	429 IN 3A	ARINC 429 Input Channel 3A
14	I	429 IN 2A	ARINC 429 Input Channel 2A
15	I	429 IN 1A / RS232 Rx D7	ARINC 429 In Channel 1A / RS232 Channel 7 serial data in
16	O	429 OUT 4A	ARINC 429 Output Channel 4A
17	O	429 OUT 3A	ARINC 429 Output Channel 3A
18	O	429 OUT 2A	ARINC 429 Output Channel 2A
19	O	429 OUT 1A	ARINC 429 Output Channel 1A
20	O	Audio Out Lo	Audio signal ground
21	O	Suppression Output	Suppression Output (active high)
22	I	TCAS Operational In	TCAS Operational Discrete Input (active low)
23	I	Air/Ground In	Air / Ground Discrete Input (level-configurable)
24	--	Serial Ground 6	RS232 signal ground
25	O	UAT Fail Out	UAT Fail Output (active low)
26	--	RESERVED	RESERVED
27	--	RESERVED	RESERVED
28	I	RS422 Rx D3 -	RS422 channel 3 serial data input -
29	O	RS422 Tx D3 -	RS422 channel 3 serial data output -
30	I	429 IN 4B	ARINC 429 Input Channel 4B
31	I	429 IN 3B	ARINC 429 Input Channel 3B
32	I	429 IN 2B	ARINC 429 Input Channel 2B
33	I	429 IN 1B / RS232 Rx D6	ARINC 429 In Channel 1B / RS232 Channel 6 serial data in
34	O	429 OUT 4B	ARINC 429 Output Channel 4B
35	O	429 OUT 3B	ARINC 429 Output Channel 3B
36	O	429 OUT 2B	ARINC 429 Output Channel 2B
37	O	429 OUT 1B	ARINC 429 Output Channel 1B

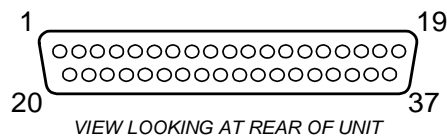

Figure 2-10. 37-pin Connector

2.8 FUNCTIONAL DESCRIPTIONS

2.8.1 POWER

Aircraft power is provided to the GDL 90 on the main system connector. The GDL 90 will accept input power from 10 to 40 VDC.

P1-1	Power +
P1-9	Power +
P1-2	Power Ground
P1-10	Power Ground

Refer to Appendix C for recommended power connections.

CAUTION

Operating the GDL 90 with no RF terminations on the Top or Bottom UAT Antenna ports can result in equipment damage. Always operate the GDL 90 with the Top and Bottom UAT Antenna ports terminated with a VSWR ratio of 3.0:1 or less.

2.8.2 MICRO AIRCRAFT PERSONALITY MODULE (APM)

The GDL 90 stores installation-specific configuration information in an aircraft personality module located on the rear of the mounting tray. This eliminates the need to set up the configuration again if a new GDL 90 is installed. Since APM contains no lightning protection, the wire length from APM to GDL 90 must be limited to 4 inches maximum.

P1-6	APM TxD
P1-7	APM RxD
P1-14	APM Gnd

Refer to Appendix C for interconnect information.

2.8.3 STATUS LEDs

The GDL 90 uses 6 LEDs mounted on the front of its enclosure to communicate system status and conditions of various internal functions. The descriptions of the LEDs, with power applied to the unit, are as follows:

Name	Description
Tx	<i>UAT Transmit</i> – normally LED blinks at once a second ON = UAT data is being transmitted OFF = No UAT transmission
Rx	<i>UAT Receive</i> ON = UAT data is being received OFF = No UAT reception
Maint	<i>Maintenance</i> ON = GDL 90 needs maintenance check at the earliest convenience OFF = No maintenance issue

Ext	<i>External connections</i> ON = One or more external systems have disconnected or failed OFF = No external system failure
GPS	<i>GPS Status</i> Flashing = GDL 90 is acquiring GPS position Steady ON = GPS position has been acquired OFF = system failure
Status	<i>GDL 90 System Status</i> ON = GDL 90 has failed. Perform troubleshooting procedure and maintenance check. OFF = GDL 90 is functioning satisfactorily.

2.8.4 DISCRETE OUTPUT

Discrete outputs can be used to drive annunciator lamps or provide status information to other equipment. Unless otherwise indicated, they are active low (i.e. grounded when active, and open otherwise) and open collector output capable of sinking up to 400 mA.

2.8.4.1 UAT Fail / GPS Status Output

P2-25 UAT Fail Out

The UAT Fail Out (P2-25) is used to indicate the status of the GDL 90 or status of its internal GPS engine. The function of this discrete output can be configured via the APM setup (refer to Section 3.0.) Using the APM initialization, the UAT Fail Out can be configured to behave as follows:

- As UAT Fail Indicator** The UAT Fail Out will be grounded when the GDL 90 has detected a system failure. This output will be open otherwise.
- This setting is typically used if installed display does not provide UAT failure annunciation, and the control panel does not provide a GDL 90 status monitor. In this case, install an annunciator lamp in the caution/warning panel.
- As GPS Status Indicator** The UAT Fail Out will be grounded when the GDL 90 has acquired valid GPS position. The UAT Fail Out will flash (i.e. alternate between being open and grounded) at a 1 Hz rate when the GDL 90 is searching but has not acquired a position. The UAT Fail Out will be open if the GDL 90 has detected a system failure.
- This setting is used for the GSL 71 Control Panel.

2.8.4.2 Transponder Suppression Output

P2-21 Suppression Out

The Suppression Out is used to indicate to on-board transponder that the GDL 90 is transmitting and therefore inhibit the transponder from transmitting. The Suppression Output is an active signal and will be active high when on-board transponder should be suppressed and grounded when transponder is free to transmit.

2.8.5 DISCRETE INPUTS

The discrete inputs can be used to provide additional status information from aircraft systems or equipment. All of these inputs are active low (i.e. grounded when active, and open otherwise). Each input presents a load of greater than 100 k Ω .

2.8.5.1 Air/Ground Discrete Input

P2-23 Air/Ground In

The Air/Ground In is used to provide the aircraft air/ground status. The function of this discrete input can be configured via the APM setup (refer to Section 3.0). Using the APM setup, the Air/Ground In can be configured in one of the following options:

- An air/ground switch is not installed.
- A 'ground' at the Air/Ground In indicates that the aircraft is on the ground, and an 'open' indicates that the aircraft is in the air.
- A 'ground' at the Air/Ground In indicates that the aircraft is in the air, and an 'open' indicates that the aircraft is on the ground.

NOTE

The air/ground status provided by the Air/Ground In may be overridden by other system inputs, such as ground speed and radio altitude (if available).

2.8.5.2 Audio Inhibit In

P2-5 Audio Inhibit In

The Audio Inhibit In is used to inhibit the GDL 90 audio messages. A ground on this input causes GDL 90 audio messages not to be played; if this input is open GDL 90 audio messages will be played.

2.8.5.3 TCAS Operational Discrete Input

P2-22 TCAS Operational In

The TCAS Operational In is used to provide operational mode information of an on-board TCAS system. A ground on this input indicates that the TCAS system is installed and operational. An open on this input indicates that the TCAS is not installed or operational.

2.8.5.4 TCAS Resolution Advisory Active Discrete Input

P2-4 TCAS RA Active In

The TCAS RA Active In is used to provide the existence of any resolution advisories that the on-board TCAS may be generating. A ground on this input indicates that a TCAS resolution advisory is currently active. An open on this input indicates that there are currently no active TCAS resolution advisories.

2.8.6 SERIAL INTERFACES

2.8.6.1 RS232 / RS422

The GDL 90 provides two bi-directional RS232 serial interfaces, up to two receive-only RS232 serial interfaces, and one bi-directional RS422 serial interface for making optional connections. The serial ports can be used for connecting to:

- Display
- External UAT control panel or Transponder
- Altitude Encoder
- Maintenance PC

P1-3	RS232 RxD1 (Maintenance PC only)	P2-15	429 IN 1A / RS232 RxD7
P1-4	RS232 TxD1 (Maintenance PC only)	P2-7	Serial Ground 7
P1-11	Serial Ground 1		
P1-12	RS232 RxD2	P2-33	429 IN 1B / RS232 RxD6
P1-13	RS232 TxD2	P2-24	Serial Ground 6
P1-5	Serial Ground 2		
P2-10	RS422 RxD3 +		
P2-28	RS422 RxD3 -		
P2-11	RS422 TxD3 +		
P2-29	RS422 TxD3 -		

NOTE

In order for a serial port to function correctly, the baud rate of the Rx and Tx channels on a given RS232 or RS422 port must be the same. This must be considered when assigning serial ports to interfacing equipment.

NOTE

The two receive-only serial ports (RxD6 and RxD7) are shared with ARINC 429 input 1. If the ARINC 429 input is used, RxD6 and RxD7 are not available.

The GDL 90 display interface always uses Port 3 (RxD3 +/- and TxD3 +/-).

The GDL 90 communicates with the maintenance PC using RS232 RxD1 and TxD1. This interface is used to program the APM and get additional system status information on the system.

The GDL 90 can receive altitude data from an altitude encoder using RS232 RxD2, RxD6, or RxD7.

An interface to an external Control Panel or Transponder always uses RS232 RxD2. The Control Panel interface can also provide altitude data to the GDL 90, if desired.

2.8.6.2 ARINC 429

The GDL 90 provides four ARINC 429 inputs and four ARINC 429 outputs. Each of these may be configured for low-speed or high-speed operation.

P2-15	429 IN 1A / RS232 RxD7	P2-19	429 OUT 1A
P2-33	429 IN 1B / RS232 RxD6	P2-37	429 OUT 1B
P2-14	429 IN 2A	P2-18	429 OUT 2A
P2-32	429 IN 2B	P2-36	429 OUT 2B
P2-13	429 IN 3A	P2-17	429 OUT 3A
P2-31	429 IN 3B	P2-35	429 OUT 3B
P2-12	429 IN 4A	P2-16	429 OUT 4A
P2-30	429 IN 4B	P2-34	429 OUT 4B

An optional ADC or AHRS source can be connected to any of the ARINC 429 inputs. If available, the GDL 90 will use the ADC/AHRS for radio altitude, pressure altitude, altitude rate, airspeed, and heading.

NOTE

The two receive-only serial ports (RxD6 and RxD7) are shared with ARINC 429 input 1. If RxD6 or RxD7 is used, ARINC 429 Input port 1 is not available.

NOTE

ARINC 429 outputs are provisioned for future versions and not currently used.

2.8.7 AUDIO

The GDL 90 provides an audio output for aural advisory messages. A discrete input is also provided to allow these audio messages to be inhibited by higher priority systems.

2.8.8 SUPPRESSION OUTPUT

P2-21 Suppression Out

The Suppression Out is intended to suppress other L-band equipment (such as a transponder) when the UAT transmits. It provides a high signal (Vin – 1.5V) whenever the UAT is transmitting, and a low signal otherwise.

NOTE

Certain transponders emit spurious replies in response to some UAT transmissions. Consequently, it is recommended that the GDL 90 suppression output be connected to the suppression input on these transponders (if available.)

2.9 WEIGHT AND BALANCE

Weight and balance computation is required after the installation of the GDL 90. Follow the guidelines as established in AC 43.13-1B, Chapter 10, Section 2. Make appropriate entries in the equipment list indicating items added, removed, or relocated along with the date accomplished. Include your name and certificate number in the aircraft records. Table 2-6 identifies the weight of the new GDL 90 equipment and Figure 2-9 shows the center of gravity.

Table 2-6. Unit Weights	
Item	Weight
GDL 90 only	5.2 lbs
GDL 90 mounting tray	1.0 lbs
GDL 90 mounting tray with optional cover	1.2 lbs
Micro APM	0.1 lbs

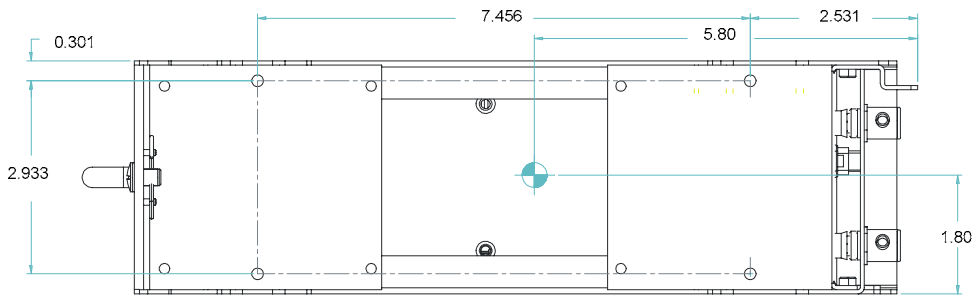
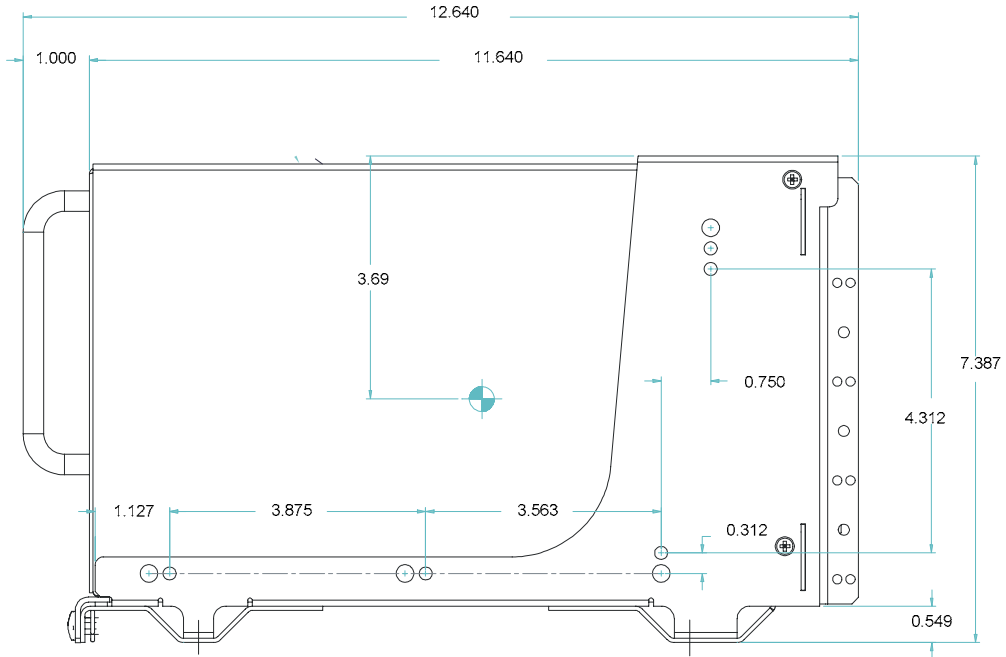

Figure 2-11. GDL 90 Center of Gravity

2.10 ELECTRICAL LOAD ANALYSIS

An electrical load analysis should be completed on each aircraft prior to installation in accordance with AC 43.13-1B, Chapter 11. Use the following values for computation:

Table 2-7. Unit Power Loads				
GDL 90 Input	14 VDC		28 VDC	
	Typical	Max	Typical	Max
GDL 90 Main Power	1.5 A	3.00	750mA	1.5

NOTE

Circuits should be protected in accordance with guidelines in AC 43.13-1B, chapter 11, Section 2, Paragraph 429.

NOTES

3 LIMITATIONS

3.1 OPERATION

The installation of a GDL 90 into an aircraft does not alter the operational approvals previously granted to that aircraft. Additional operation approvals may require FAA evaluation of all the systems installed in a particular aircraft and is outside the scope of the GDL 90 STC.

3.2 INSTALLATION

The conditions and test required for TSO approval of this article are minimum performance standards. It is the responsibility of those installing this article either on or within a specific type or class of aircraft to determine that the aircraft installation conditions are within the TSO standards. TSO articles must have separate approval for installation in an aircraft. The article may be installed only if performed under 14 CFR Part 43 or the applicable airworthiness requirements.

3.2.1 SURVEILLANCE SERVICES

In some regions of the U.S. National Airspace, surveillance services (e.g. flight following, IFR separation) are available through the UAT data link. If such services are desired, the GDL 90 installation should be designed such that the flight crew has a single point of entry for the ATC-assigned squawk code. The following points should be considered:

- If the aircraft is not transponder equipped, then an MX20 display or GSL 71 Control Panel may be configured to provide for squawk code entry. See the installation manuals for those products for detailed instructions.
- If the aircraft is equipped with a compatible transponder, the GDL 90 can be configured so that the transponder acts as the GDL 90 control panel. Compatible transponders include the Apollo SL70, the Garmin GTX 327 (Mode A/C), and GTX 330 (Mode S) units.

If these transponders are remotely controlled by other equipment, such as a GNS 480 (Apollo CNX80), the GDL 90 may be connected to the transponder control interface to obtain the control information.

The TCAS interface is not currently approved for installation or use. The APM shall be configured as "TCAS not installed".

3.2.2 GPS ANTENNA

The GDL 90 is only compatible with the Garmin AT A-33 (590-1104) or A-34 (590-1112) antennas, or those with equivalent specifications. Refer to section 1.3.7.1 for specifications.

Testing has demonstrated GDL 90 compatibility with SatCom installation in the aircraft, if cable loss is as specified Section 2.6.1.

3.2.3 UAT ANTENNA

The GDL 90 requires at least one UHF antenna meeting the following specifications:

- Standard 50Ω vertically polarized antenna with a VSWR < 1.7:1 at 978 Mhz
- TSO-C66, C74, C112 or C154 antennas that also meet the VSWR specification
Garmin AT P/N 590-0051 or P/N 590-0052 antenna meet these requirements.

CAUTION

Operating the GDL 90 with no RF terminations on the Top or Bottom UAT Antenna ports can result in equipment damage. Always operate the GDL 90 with the Top and Bottom UAT Antenna ports terminated with a VSWR ratio of 3.0:1 or less.

3.2.4 ANTENNA INSTALLATION – GENERAL

Antenna installation in the pressure vessel of pressurized aircraft is beyond the scope of the GDL 90 STC. Additional manufacturer's data may be necessary and FAA approval may be required to cover the installation of any antenna in the pressure vessel of a pressurized aircraft.

3.2.5 EQUIPMENT INTERFACED TO THE GDL 90

Any aircraft systems, other than those shown in this installation manual, that interface to the GDL 90 are outside the scope of this manual and may require further evaluation and/or certification approval.

All equipment interfaced to the GDL 90 must be previously or concurrently approved.

3.2.6 TRAFFIC DISPLAY

If the GDL 90 is interfaced to a display that uses the GDL 90 Traffic Alert function, the display Pilot's Guide must contain the following information:

Traffic Alerting is only provided for target aircraft that report an integrity value (or containment radius) of less than 1.0 nautical miles. Traffic position reports are provided for all targets regardless of their integrity. Traffic that is not eligible for traffic alerting is depicted using an appropriate display icon.

3.2.7 PRESERVATION OF PREVIOUS SYSTEMS

It is the installer's responsibility to preserve the essential characteristic of the aircraft being modified by this manual to be in accordance with the aircraft manufacturer's original design. This includes the preservation of multiple power buses, which reduce the probability of interrupting power to essential instruments and avionics.

4 POST INSTALLATION CONFIGURATION & CHECKOUT PROCEDURES

Once the GDL 90 unit has been installed, configure the unit for the particular installation and then complete these checkout procedures to verify proper operation for continued airworthiness. The steps that are not applicable to a particular installation may be skipped. A checkout log sheet, included on page 4-13, is to be filled out during the checkout procedure. The completed checkout log sheet should be maintained with the aircraft permanent records.

CAUTION

Operating the GDL 90 with no RF terminations on the Top or Bottom UAT Antenna ports can result in equipment damage. Always operate the GDL 90 with the Top and Bottom UAT Antenna ports terminated with a VSWR ratio of 3.0:1 or less.

4.1 MOUNTING AND WIRING CHECK

Verify that all cables are properly secured and shields are connected as the install drawings indicate. Installation may require that you check the movement of the aircraft controls to verify that there is no interference.

4.2 EQUIPMENT SETUP AND CONFIGURATION

Prior to system operation, the GDL 90 must be configured for the particular installation. The system setup and checkout functions are accessed by connecting a PC or terminal to the GDL 90 serial maintenance port (P1-3 and 4, RS232 RxD1 and TxD1, 38400 baud rate, 8-bit data, 1 stop bit, no parity, no flow control) and using commands as described in the following sections.

4.2.1 MAINTENANCE MODE

The GDL 90 Maintenance port allows access to the following functions:

- Program/view GDL 90 APM settings
- View GDL 90 system status
- View the status of the GDL 90 external inputs
- View status of GPS/WAAS Engine
- View version numbers

Available commands are summarized in Table 4-1. Commands are not case-sensitive (some characters in commands described in this section are capitalized to improve readability). Within a command, fields and parameters (indicated by <P>) are separated by spaces.

<i>Command</i>	<i>Parameters</i>	<i>Description</i>
Help	none	Display list of available commands
APMinit	none	Start the APM initialization routine
APMread	none	Display APM settings
Discrete	none	View discrete inputs & outputs
External	none	View status of connected external systems
GPSstatus	<P>	Monitor GPS status
PlayAudio	none	Test audio output
Reset	none	Restart the unit
RxData	<P>	View received message information
RxMsg	none	View number of good messages in 1 second
Service	none	View service information
Version	none	View software versions

Table 4-1. Maintenance Mode Commands

4.2.1.1 Help

This command causes the GDL 90 to display a list of available commands and their brief descriptions, as listed in Table 4-1.

4.2.1.2 APMinit Command

This command starts the APM initialization procedure, which leads the user step by step in configuring the GDL 90 installation. The user can quit the initialization procedure at any time (by typing ‘quit’); however the APM changes will not be saved. The new APM settings take effect when the initialization process is completed and the GDL 90 is restarted (by either cycling the power, or typing the ‘reset’ command).

Detailed instructions on the APM initialization procedure are in section 4.2.2.

4.2.1.3 APMread Command

The APMread command displays the current APM settings. An example of APM settings is shown below:

```
>apmread
Field Name                Option
-----
APM Map Version           011
ICAO Address              (see aircraft data)
Anonymous Mode            Available
Airplane Call Sign       (see aircraft data)
Capstone Feature          Enabled
Aircraft Category        light
Aircraft Length           30 feet
Aircraft Width            30 feet
Air/Ground Threshold Speed 35 kts
Serial 422 Interface      Traffic Alert
Serial 422 Baud Rate      38400
Serial 422 Ground Uplinks 2
Control Panel Source      RxD Port 2 with baud rate 1200
Pressure Altitude Source  None
Radio Altitude Source     None
ADC                       Not installed
AHRS                      Not installed
TCAS                      Not installed
Air/Ground Indication     Not Used
Audio Volume              31
Fail Annunciator          UAT fail light
Transmit Only             Tx/Rx
Antenna Mode              Top
Top Antenna Delay         0 ns
Bottom Antenna Delay      0 ns
DC-Grounded UAT Antenna   Yes
GPS Antenna Delay         0 ns
GPS Antenna Length Offset 0 feet
GPS Antenna Width Offset  0 feet
WAAS as SBAS              Enabled
```

4.2.1.4 Discrete Command

The Discrete command displays the states of the GDL 90 discrete inputs and outputs.

```
>discrete
```

4.2.1.5 External Command

The External command displays status of the connections to external systems. This is intended for checking system wiring and status of external systems.

```
>external
```

4.2.1.6 GPSstatus Command

The GPSstatus command displays the current status and data from the internal GPS Engine.

>gpsstatus <P>

<P>	Description
Once / On / Off	ONCE = output the current GPS status once ON = output GPS status once every second OFF = stop outputting GPS status

Response includes the date and time, GPS solution and position, the numbers of tracked and visible satellites, GPS performance metrics, and individual GPS channel status.

4.2.1.7 Playaudio Command

The Playaudio command causes the GDL 90 to output 1 kHz tone for a second. This allows for testing the audio connections in the aircraft.

> playaudio

The audio volume level is adjusted using the “Audio Volume” parameter in the APM. A setting of 20 to 25 is typical, but should be adjusted as necessary for each installation. Since the audible traffic alerts are played at a lower volume than the 1 KHz test tone, the APM Audio Volume setting should be increased slightly (approximately 5 points) above the level found using the 1 KHz test tone.

4.2.1.8 Reset Command

The Reset command causes the GDL 90 to perform a software restart.

>reset

4.2.1.9 Rxdata Command

The Rxdata command displays information about the received UAT radio messages.

>rxdata <P1>

<P>	Description
Summary/Details/Off	SUMMARY = Display a count of the number of each type of message received in each second. DETAILS = Display detailed information about each message received. OFF = stop outputting rxdata status

4.2.1.10 Rxmsg Command

The Rxmsg command displays the number of each type of messages (Basic, Long, and Ground Blocks) received in previous second. Each Uplink message consists of six Ground Blocks. The number of data errors corrected in each type of message is also displayed.

>rxmsg

4.2.1.11 Service Command

The Service command causes service information to be returned. It is useful for troubleshooting system failure or malfunction.

>service

4.2.1.12 Version Command

The Version command displays version numbers of the Application software, Main I/O Board FPGA, Rx Logic FPGA, PLD, Micro APM software, Radio-controller software and GPS Engine software.

>version

4.2.2 MICRO APM INITIALIZATION PROCEDURE

This section describes the procedure for initializing the GDL 90 APM. Each of the APM parameters is described in Table 4-2. The APM initialization procedure is context-sensitive; some of the settings are optional and are omitted as necessary. Some of the APM settings are not used at this time, and are reserved for future use.

When the GDL 90 software is upgraded, the old APM settings are maintained where possible. Any conflicting APM settings are set to default values. After a software upgrade, always check the APM settings (particularly those for Control Panel and Altitude Source) and verify or restore the appropriate settings for the installation.

For each setting, the character 'x' indicates that the selection is from a list of options, or is a fixed-length field.

The text <int> indicates to enter a value from within a range.

Settings	Format	Description
<i>ICAO Address</i>	xxxxxxx	Eight octal digits. All eight digits must be entered.
<i>Anonymous Mode</i>	x	0 = not available 1 = available This setting controls whether the UAT "anonymity" feature is available. When enabled and anonymous mode is selected by the flight crew, the GDL 90 transmits a temporary address instead of using the aircraft ICAO address. Consult the aircraft operator for guidance on whether this feature should be enabled.
<i>Aircraft Call Sign</i>	xxxxxxx	Eight characters defining aircraft call sign. Valid characters are A-Z, 0-9, and trailing space. Enter # if call sign is not available.
<i>CAPSTONE feature</i>	x	0 = disabled 1 = enabled Enable/disable the Capstone (Squawk Code) features.

Settings	Format	Description
		Refer to Section 3.2 for more explanation of this setting.
<i>Aircraft Category</i>	x	Code for aircraft category, from 0 to 18 0 = No aircraft type information 1 = Light (ICAO) < 15 500 lbs 2 = Small - 15 500 to 75 000 lbs 3 = Large - 75 000 to 300 000 lbs 4 = High Vortex Large (e.g., aircraft such as B757) 5 = Heavy (ICAO) - > 300 000 lbs 6 = Highly Maneuverable > 5G acceleration and high speed 7 = Rotorcraft 8 = (Unassigned) 9 = Glider/sailplane 10 = Lighter than air 11 = Parachutist/sky diver 12 = Ultra light/hang glider/paraglider 13 = (Unassigned) 14 = Unmanned aerial vehicle 15 = Space/transatmospheric vehicle 16 = (Unassigned) 17 = Surface vehicle — emergency vehicle 18 = Surface vehicle — service vehicle
<i>Aircraft Length & Width</i>	<int> <int>	<length> <width>, range 1 to 300 in feet Enter the length and width (wingspan) of the aircraft.
<i>Air/Ground Threshold Speed</i>	<int>	30 to 100 kts. For light aircraft (category 1), if Air/Ground Indication is “not available”, this threshold speed is used to determine air/ground status of aircraft. Recommended that this be set to 75% of stall speed. For all categories, if zero is entered and Air/Ground Indication is “not available”, the aircraft will always report as Airborne.
<i>Serial 422 Interface</i>	x	0 = none 1 = MX20 2 = Traffic Alert 3 = Pass-through Typically a display is installed on the serial 422 interface. Consult the display installation manual for more information.
<i>Serial 422 baud rate</i>	x	0 = 38400 1 = 57600 2 = 115200 Selection for Traffic Alert and Pass-through modes.
<i>Serial 422 Uplinks</i>	x	Select from 0, 2, or 4 uplinks per second. Selecting 2 uplinks per second is typical (default for MX20).

Settings	Format	Description
<i>Control Panel source</i>	x	0 = none 1 = via serial 422 2 = SL70/GSL 71 (Public ICD) 3 = GTX 327 or GTX 330 Indicates how GDL 90 obtains flight crew inputs.
<i>Control Panel baud rate</i>	x	0 = 1200 baud 1 = 9600 baud Selection for SL70/GSL 71 option. Baud rate is fixed for other control panel types.
<i>Pressure Altitude source</i>	x	0 = none 1 = RxD Port 2 2 = via Serial 422 3 = via an ARINC-429 device 4 = RxD Port 6 5 = RxD Port 7 Indicates how GDL 90 obtains altitude information.
<i>Pressure Altitude baud rate</i>	x	0 = 1200 baud 1 = 9600 baud Selection for RxD Port 2, Port 6 and Port 7
<i>Radio Altitude or Height Above Terrain source</i>	x	0 = none 1 = via Serial 422 2 = via an ARINC-429 device Indicates how GDL 90 obtains radio altitude or height above terrain information.
<i>ARINC 429 ADC port setup</i>	x y	x: 1 = port 1 2 = port 2 3 = port 3 4 = port 4 0 = not installed y: L = Low speed H = High speed Indicates how ADC interfaces to the GDL 90. Ex: (1 L) indicates ADC is connected through port 1 and it's a low-speed ARINC 429.
<i>ARINC 429 AHRS port setup</i>	x y	x: 1 = port 1 2 = port 2 3 = port 3 4 = port 4 0 = not installed y: L = Low speed H = High speed Indicates how AHRS interfaces to the GDL 90. Ex: (2 H) indicates AHRS is connected through port 2 and it's a high-speed ARINC 429.
<i>TCAS installation</i>	x	0 = TCAS not installed 1 = TCAS installed without interface (to GDL 90) 2 = TCAS installed with interface (to GDL 90) The TCAS interface is not currently approved for installation or use. "0" must be entered for TCAS not installed. See Section 3.2.

Settings	Format	Description
<i>Air/Ground Indication</i>	x	0 = airborne open 1 = on-ground open 2 = not used If GDL 90 is connected to the aircraft's air/ground switch, enter the orientation of the switch. Enter 2 if an air/ground switch is not available.
<i>Audio Volume</i>	x	range: 0 (off) to 31 (max) Sets the audio level output from GDL 90.
<i>UAT Failure Annunciator</i>	x	0 = as UAT Fail Indicator 1 = as GPS Valid / GDL 90 Fail indicator The GDL 90's UAT Fail discrete output can be set to function in 2 different ways. Refer to Section 2.8.4.1 for more details.
<i>Transmit Only</i>	x	0 = Tx/Rx 1 = Tx-only Indicates whether the GDL 90 is installed as a transceiver (Class A1H), or only as a transmitter (Class B1).
<i>UAT Antenna mode</i>	x	0 = dual 1 = top-only 2 = bottom-only Indicates whether the GDL 90 is connected to 1 or 2 antennas.
<i>Top UAT Antenna Delay</i>	<int>	0 to 65534 in nanoseconds It's recommended that zero be entered for most installations where antenna cable is not excessively long.
<i>Bottom UAT Antenna Delay</i>	<int>	0 to 65534 in nanoseconds It's recommended that zero be entered for most installations where antenna cable is not excessively long.
<i>DC-grounded UAT antenna</i>	x	N = no Y = yes Indicates whether the installed UAT antenna(s) can be tested by the GDL 90's grounding the antenna(s).
<i>GPS Antenna Delay</i>	<int>	0 to 65534 in nanoseconds It's recommended that zero be entered for most installations where antenna cable is not excessively long.
<i>Aircraft GPS Antenna Length & Width Offset</i>	<int> <int>	<length offset> <width offset> 0 to 200 feet Length offset = distance from aircraft nose to GPS antenna Width offset = distance from aircraft center line to GPS antenna
<i>WAAS as SBAS</i>	x	0 = disabled 1 = enabled Controls whether GDL 90 GPS engine uses WAAS signals for SBAS (Satellite Based Augmentation System) corrections.

Table 4-2. Data Items for APM initialization

4.2.3 MICRO APM CONFIGURATION WORKSHEET

Use this table as a worksheet for determining the desired APM settings. Save the worksheet for future reference.

Settings	Format	Value & Notes
ICAO Address	XXXXXXXX	
Anonymous Mode	x	
Aircraft Call Sign	XXXXXXXX	
CAPSTONE feature	x	
Aircraft Category	x	
Aircraft Length & Width	<int> <int>	
Air/Ground Threshold Speed	<int>	
Serial 422 Interface	x	
Serial 422 baud rate	x	<i>for Traffic Alert and Pass-through interfaces only</i>
Serial 422 Uplinks	x	<i>for Traffic Alert and Pass-through interfaces only</i>
Control Panel source	x	
Control Panel baud rate	x	<i>for SL70 / GSL 71 only</i>
Pressure Altitude source	x	
Pressure Altitude baud rate	x	<i>for RxD2, RxD6, and RxD7 only</i>
Radio Altitude or Height Above Terrain source	x	
ARINC 429 ADC port setup	x y	<i>Port 1 not available if RxD6 or RxD7 is used</i>
ARINC 429 AHRS port setup	x y	<i>Port 1 not available if RxD6 or RxD7 is used</i>
TCAS installation	x	Enter 0 only
Air/Ground Indication	x	
Audio Volume	x	
UAT Failure Annunciator	x	
Transmit Only	x	
UAT Antenna mode	x	
Top UAT Antenna Delay	<int>	
Bottom UAT Antenna Delay	<int>	
DC-grounded UAT antenna	x	
GPS Antenna Delay	<int>	
Aircraft GPS Antenna Length & Width Offset	<int> <int>	
WAAS as SBAS	x	

4.2.4 MX20 SETUP

If the GDL 90 is used in conjunction with a Garmin MX20 Multi-function Display, the MX20 should be configured accordingly. For instructions, refer to the MX20 User Guide (Part No. 560-1026-06 or later FAA-approved revision), which is included in the GDL 90 Product CD. The GDL 90 is intended for use with MX20 software Version 5.3 or later.

If the control panel (GSL 71 or a Transponder) is used for squawk code entry, the MX20 configuration should be set to disable the “Capstone” (Squawk code) feature.

4.3 EQUIPMENT OPERATIONAL/FUNCTIONAL TEST

4.3.1 SYSTEM CHECKOUT – GROUND CHECKS

The GDL 90 executes a self test at power-up to verify the unit operation as well as other internal functions. Failures and system status are recorded and communicated via 6 LEDs in the front of the unit. Verify that the unit does not display a failure indication when turned on.

The GDL 90 must be properly configured prior to performing system checkouts. When configured correctly, the GDL 90 will annunciate failures that are detected with interfacing systems when it is first turned on. Any annunciated failures should be corrected prior to proceeding with the ground checks

4.3.1.1 GPS Navigation Checkout

Following configuration of the APM, the aircraft should be moved to a location with an unobstructed view of the available GPS satellites. A computer must be connected to the maintenance port to verify position and signal strength information.

Check the GPS operation as follows:

1. Connect a computer to the 9-pin maintenance port connector (Refer to Section 4.2.)
2. Turn on the GDL90 and allow the unit to acquire a position. Verify that the GPS LED on the front of the GDL 90 stops blinking and remains steadily lit within 20 minutes of power-on, indicating unit has acquired a 3-D fix. All other avionics should be turned off for this part of the test.
3. Check the position using the GPSstatus command. The displayed lat/lon should agree with a known reference position.
4. Turn on other avionics one at a time and verify that the GPS LED remains steady on.
5. Check for VHF comm transmitter interference.

NOTE

The interference check must be completed on all IFR installations.

- a) Tune the Com 1 radio to 121.125 MHz. Listen on the frequency to ensure it is not in use, and then transmit for 30 seconds.
- b) While transmitting, observe the ‘GPS’ LED. Verify that the GPS LED remains steady on. If not, additional isolation measures will have to be taken.

- c) Repeat steps a) and b) for additional frequencies as follows.

121.150 MHz	131.225 MHz
121.175 MHz	131.250 MHz
121.185 MHz [1]	131.275 MHz
121.190 MHz [1]	130.285 MHz [1]
121.200 MHz	131.290 MHz [1]
121.225 MHz	131.300 MHz
121.250 MHz	131.325 MHz
131.200 MHz	131.350 MHz

[1] frequency is only applicable to VHF radios with 8.33 kHz channel spacing

- d) Repeat for each com transmitter installed in the aircraft.
- e) If aircraft is TCAS-equipped, turn on the TCAS system and verify that GPS LED remains steady on.
- f) If aircraft is SATCOM-equipped, use the SATCOM system and verify that GPS LED remains steady on.
- g) If the GDL 90 is susceptible to VHF Com transmitter interference, then better isolation (or greater separation) may be required between the GPS and VHF (or other offending system) antennas. With some com transmitters, a 1575.42 MHz notch filter (such as Garmin AT P/N 162-1059) may be required in series with the VHF Com antenna coax at the rear of the com unit. ELT's may re-radiate harmonics of the VHF Com signal into the GPS band. A 1575.42 MHz notch filter on the ELT will solve this.

NOTE

Older VHF Com transmitters may emit higher levels of harmonic interference.

4.3.1.2 Interface Checkout

This section describes checks that can be carried out to verify that systems interfacing to the CNX80 are communicating properly.

4.3.1.2.1 Air Data Computer and Altitude Encoder

Verify that the Ext LED on the front of the GDL 90 is not illuminated.

4.3.1.2.2 Display Checkout

Refer to the display installation manual for checkout procedures.

If an MX20 is used as the display, refer to the MX20 installation manual (P/N 560-1025-08 or later FAA approved revision) for detailed procedures on the following checks:

- With the MX20 in Installer mode, select the FUNC pages and verify that all functions are enabled except for lightning.
- Go to the DATA pages and configure the MX20 as follows:

UAT Traffic Data Link Source	Port 4
------------------------------	--------
- Select the MISC pages. Press the NEXT PAGE menu key
- Set GDL 90 UAT Radio to ENABLED
- Set GDL 90 Code Edit to ENABLED
- Wait at least 30 seconds (until red message no longer appears at the bottom of the screen) and then recycle power to the MX20. Wait another 30 seconds and verify that the TRAF warning does not appear.

4.3.1.2.3 Control Panel Checkout

Use this procedure if an external control panel function is used, such as a GSL 71, or an interface to a transponder.

Verify that the Ext LED on the front of the GDL 90 is not illuminated.

4.3.1.2.4 Display Interface Checkout

If the GDL 90 is interfaced to a display unit, verify that the Ext LED on the front of the GDL 90 is not illuminated.

4.3.1.3 Annunciator Checkout

Disable the traffic display. The GDL 90 Status LED should turn ON within 5 seconds, and the UAT Fail Out indication should activate. The indication can be either through a annunciator lamp or via the GSL 71 control panel indication, depending on the GDL 90 configuration.

Table 4-3. GDL 90 Post-Installation Checkout Log

GDL 90 Post-Installation Checkout Log		Date: ___/___/___
		By: _____
		430-6081-1 _____ - _____ HW Mod _____
		Serial # _____ SW Mod _____
SETUP ITEMS:		
<i>Serial Interface Configuration (RX/TX):</i>		
Reserved for maintenance PC	(Port 1)	_____ <input type="checkbox"/> Hi <input type="checkbox"/> Low (Channel 1 In)
_____ / _____	(Port 2)	_____ <input type="checkbox"/> Hi <input type="checkbox"/> Low (Channel 2 In)
<input type="checkbox"/> Display interface	(Port 3)	_____ <input type="checkbox"/> Hi <input type="checkbox"/> Low (Channel 3 In)
_____ / _____	(Rx Port 6)	_____ <input type="checkbox"/> Hi <input type="checkbox"/> Low (Channel 4 In)
_____ / _____	(Rx Port 7)	_____ <input type="checkbox"/> Hi <input type="checkbox"/> Low (Channel 4 In)
<i>ARINC 429 Input Configuration:</i>		
ANNUNCIATOR OUTPUTS CHECKOUT:		
UAT Fail Annunciator:		
<input type="checkbox"/> UAT Fail; <input type="checkbox"/> GPS Indicator		
<input type="checkbox"/> Annunciator lamp installed		
Suppression Out: <input type="checkbox"/> connected to transponder		
DISCRETE INPUTS CHECKOUT:		
<input type="checkbox"/> [<input type="checkbox"/> N/A] Air / Ground Switch		
GPS NAVIGATION CHECKOUT		
<input type="checkbox"/> Position checked		<input type="checkbox"/> Interference from other avionics checked
<input type="checkbox"/> Signal reception checked		<input type="checkbox"/> VHF com interference checked
INTERFACE CHECKOUT		
<input type="checkbox"/> [<input type="checkbox"/> N/A] Transponder		
<input type="checkbox"/> [<input type="checkbox"/> N/A] Altitude Encoder		
<input type="checkbox"/> [<input type="checkbox"/> N/A] Display		
<input type="checkbox"/> [<input type="checkbox"/> N/A] Control Panel		
FLIGHT CHECKS:		
<input type="checkbox"/>		
FINAL SYSTEM CHECK:		
<input type="checkbox"/>		
COMMENTS:		

NOTES

5 TROUBLESHOOTING

This section provides information to assist troubleshooting if problems occur after completing the installation. Use Table 5-1 and flowcharts in Appendix B to assist in troubleshooting. A PC connected to the GDL 90 Maintenance port is essential in troubleshooting. In addition, devices connected to the GDL 90, such as a control panel or display can be useful for determining whether the GDL 90 is functioning properly or if there are problems with the installation.

5.1 TROUBLESHOOTING PROCEDURE

Table 5-1. Troubleshooting Guide		
Problem	Possible Cause	Solution
No LED activity	1. No power to unit.	1. Verify that power and ground leads are correct and power is getting to unit.
No targets are shown on the display.	1. No targets are transmitting ADSB. 2. No targets are within line-of-sight range. 3. Antennas and cables are not connected. 4. Display is not connected.	1. Verify that other targets are transmitting ADSB. 2. Verify that other targets are within line-of-sight range. 3. Verify that antennas and cables are connected properly. 4. Verify Ext LED is not lit.
Your aircraft is not displayed on other aircraft MFD.	1. Transmit malfunction.	1. Verify that Tx LED on the GDL 90 blinks at least once per second.
Tx LED is not on (flashing at 1 Hz rate).	1. Unit is not transmitting UAT messages.	1. Verify antennas and cables are properly connected.
Rx LED is not on.	1. Unit is not receiving UAT messages.	1. Verify antennas and cables are properly connected and that other UAT-equipped aircraft is transmitting.
Maint LED is on.	1. Maintenance check may be needed.	1. Use the Service command in Maintenance mode to verify system condition. Consult dealer or factory technician for recommended action. See Appendix B and Section 5.2 for procedures.
Ext LED is on.	1. External system(s) or connections to those systems have failed.	1. Use the External command in Maintenance mode to determine which system(s) or connection(s) has failed. Verify wiring, connector and health status of the failed system(s). See Appendix B and Section 5.2 for procedures.
GPS LED is not on.	1. System or GPS failure	1. Use the Service command in Maintenance mode to verify system condition. If the Status LED is also lit, return unit to Factory for repair.
Status LED is on, without Maint or Ext LEDs.	1. System malfunction or failure	1. Return unit to Factory for repair. Refer to Section 5.3 for procedure to follow.

5.2 COLLECTING ADDITIONAL INFORMATION

This section contains a summary of the messages produced by the “service” and “external” Maintenance port commands. Some brief comments are included for each group of commands that may help in troubleshooting efforts.

5.2.1 MESSAGES FOR SERVICE COMMAND

The “service” command can produce Messages 001 up to 059.

"MSG 001: Invalid messages from Radio Controller"

"MSG 002: No messages from Radio Controller."

"MSG 003: No response from Radio Controller."

Comment: These messages indicate a problem with the internal radio assembly. Contact the factory.

"MSG 004: Invalid transmit processing time."

Comment: This indicates a temporary software timing limitation. There is no need to contact the factory unless the problem is persistent.

"MSG 005: Invalid ownship transmit loopback."

Comment: This indicates a connection problem between the UAT transmitter and receiver. Contact the factory.

"MSG 006: Transmit output power failure."

"MSG 007: No PLL lock indication."

Comment: Persistent occurrence of these messages indicates a problem with the internal radio assembly. Contact the factory.

"MSG 008: NVRAM battery low."

Comment: The GDL 90 internal battery needs to be replaced. Contact the factory.

"MSG 009: APM map version is old."

Comment: The GDL 90 software is a newer version than the APM was configured with. The “APMinit” procedure should be used to update the APM map, and correct any undefined settings.

"MSG 010: APM Invalid Product ID."

"MSG 011: Invalid value in the APM ICAO address field."

"MSG 012: Invalid value in the APM Aircraft Category field."

"MSG 013: Invalid value in the APM antenna mode field."

"MSG 014: Invalid value in the APM grounded antenna field."

"MSG 015: APM CRC check has failed."

"MSG 016: Receive invalid messages from APM."

Comment: These messages all indicate a problem with the APM data contents. Contact the factory.

"MSG 018: GPS engine has failed."

Comment: This message indicate a problem with the internal GPS receiver . Contact the factory.

"MSG 019: Missed ownship transmit loopback."

Comment: There is no need to call the factory unless the problem is persistent, or other problems are reported as well.

5.2.2 MESSAGES FOR EXTERNAL COMMAND

The “external” command can produce Messages 060 and higher.

"MSG 060: One of antenna BITE tests has failed."

"MSG 061: All antenna BITE tests have failed."

Comment: On the maintenance port, enter the command “log current” for more information on which antenna has failed.

"MSG 062: Control panel is not detected."

"MSG 063: Control panel has failed (no heartbeat)."

Comment: The Control Panel or its interface to the GDL 90 is not working correctly. Check the Control Panel installation and APM configuration.

"MSG 064: No valid data from the Altitude Encoder."

"MSG 065: No valid altitude available."

Comment: The altitude encoder or its interface to the GDL 90 is not working correctly. Check the altitude encoder installation and APM configuration.

"MSG 066: Display has failed."

Comment: The GDL 90 is not receiving Initialization messages from the display. Check the display installation and its configuration, and the APM configuration.

"MSG 067: No response from APM."

Comment: The APM is not communicating with the GDL 90. Check the APM installation (flying wires connected to the correct pins on P1). Contact the factory if the problem cannot be resolved.

"MSG 068: ADC/AHRS interface timeout."

Comment: The GDL90 is not receiving the expected ARINC words from the ADC or AHRS. Check the equipment installation and wiring, and the APM configuration. Contact the factory if the problem cannot be resolved.

5.3 CONTACTING THE FACTORY FOR ASSISTANCE

If the GDL 90 unit fails to operate despite troubleshooting efforts, contact Garmin AT Technical Support for assistance.

Garmin AT, Inc.
2345 Turner Rd. SE
Salem, Oregon 97302
USA

Phone: 503.581.8101 or 800.525.6726 (ext. 3991)
<http://www.garmin.com>

Be prepared to offer the following information about the installation:

- Installation configuration (list of any accessories)
- Model number, part number with mod levels, and serial number
- Software Versions
- Description of problem
- Efforts made to isolate the problem

Technical support via email is available at the following address: support.salem@garmin.com

Please attach a file containing a text capture from the GDL 90 Maintenance port that includes the responses to the following commands (without the quotes):

"version"
"apmread"
"service"
"external"

6 PERIODIC MAINTENANCE

This section contains information on periodic calibration and maintenance required for continued airworthiness.

6.1 EQUIPMENT CALIBRATION

No scheduled servicing tasks or internal manual adjustments are required on the GDL 90.

6.2 CLEANING

The GDL 90 does not require regular cleaning.

6.3 BATTERY REPLACEMENT

The GDL 90 includes an internal battery that will last about 10 years. The battery is used for internal RAM memory and GPS system information. Regular planned replacement is not necessary. The GDL 90 Maint. LED will be lit when replacement is required. To verify that the battery needs replacing, use the “Service” command in Maintenance Mode. Once low battery is confirmed, the battery should be replaced within 1 to 2 months.

If the battery is not replaced and becomes totally discharged, the GDL 90 will remain fully operational, but the GPS signal acquisition time will be increased. There is no loss of function or accuracy of the GDL 90 with a discharged battery.

The battery is not user-replaceable. To replace the battery, contact the Garmin AT repair station.

6.4 ALTITUDE SOURCE

The GDL 90 requires that the source of altitude input data undergo periodic test and calibration, similar to that required for the altitude provided to a transponder. The altitude encoder must be calibrated every 24 months as described in FAR 91.411, for the intended usage of situational awareness or visual acquisition and IFR separation. Refer to the manufacturer’s calibration or installation manual.

NOTES

APPENDIX A - CERTIFICATION DATA

A.1 GDL 90 ENVIRONMENTAL QUALIFICATION - FIXED-WING

For fixed-wing installations, the GDL 90 has been tested to the following environmental categories per procedures defined in RTCA/DO-160D.

Environmental Qualification Form			
Nomenclature: GDL 90 Part No.: 430-6081-100-xxx HW Mod "None" and "A" TSO No.: C145a, C154		Manufacturer: Garmin AT 2345 Turner Road SE Salem, Oregon 97302	
Environment	Section	Category	Comment
Temperature and Altitude	4	F1 & A1	Operating temp -20°C to +55°C Short time hi temp to +70°C Ground survival temp -55°C to +85°C Altitude 55,000 feet Decompression 55,000 feet Overpressure Loss of cooling test -- not required No external cooling required provided internal fans are unobstructed and operating
Temperature Variation	5	B	Minimum 5°C per minute
Humidity	6	B	Severe humidity environment.
Operational Shocks and Crash Safety	7	B5R	meets operational and crash safety shock tests 20 Gs at 11 ms.
Vibration	8	S(M & B)	Standard vibration. Meets without shock mounts.
Explosion Proofness	9	X	not applicable, no test required
Waterproofness	10	X	not applicable, no test required
Fluids Susceptibility	11	X	not applicable, no test required
Sand and Dust	12	X	not applicable, no test required
Fungus Resistance	13	X	not applicable, no test required
Salt Spray	14	X	not applicable, no test required
Magnetic Effect	15	Z	< 0.3 meter
Power Input	16	A & B	for 28 and 14 volt systems
Voltage Spike	17	A	
Audio Frequency Conducted Susceptibility - Power Inputs	18	Z	
Induced Signal Susceptibility	19	C	
Radio Frequency Susceptibility (Radiated and Conducted)	20	UV- [1]	Equipment tested to Category U (Conducted) Equipment tested to Category V (Radiated) No Pulse tests performed.
Emission of Radio Frequency Energy	21	M	
Lightning Induced Transient Susceptibility	22	A3XX	Equipment tested to pin test waveform set A, level 3. No cable bundle test required.
Lightning Direct Effects	23	X	not applicable, no test required
Icing	24	X	not applicable, no test required
Electrostatic Discharge (ESD)	25	A	

[1] The GDL 90 passes Category V (Radiated) for all TSO functions except temporary degraded receiver sensitivity at one frequency in the 2 to 3 GHz band.

A.2 GDL 90 ENVIRONMENTAL QUALIFICATION - ROTORCRAFT

For rotorcraft installations, the GDL 90 has been tested to the following environmental categories per procedures defined in RTCA/DO-160D. This environmental qualification also includes Waterproofness and Salt Spray approvals.

Environmental Qualification Form			
Nomenclature: GDL 90 Part No.: 430-6081-100-xxx HW Mod "B" TSO No.: C145a, C154		Manufacturer: Garmin AT 2345 Turner Road SE Salem, Oregon 97302	
Environment	Section	Category	Comment
Temperature and Altitude	4	F1 & A1	Operating temp -20°C to +55°C Short time hi temp to +70°C Ground survival temp -55°C to +85°C Altitude 55,000 feet Decompression 55,000 feet Overpressure Loss of cooling test -- not required No external cooling required provided internal fans are unobstructed and operating
Temperature Variation	5	B	Minimum 5°C per minute
Humidity	6	B	Severe humidity environment.
Operational Shocks and Crash Safety	7	B5R	meets operational and crash safety shock tests 20 Gs at 11 ms.
Vibration	8	S(M & B) U(F & F1)	Standard vibration. Meets without shock mounts. Robust vibration. Meets without shock mounts. Vertical mounting only for robust vibration.
Explosion Proofness	9	X	not applicable, no test required
Waterproofness	10	W	Drip proof test. Vertical mounting only.
Fluids Susceptibility	11	X	not applicable, no test required
Sand and Dust	12	X	not applicable, no test required
Fungus Resistance	13	X	not applicable, no test required
Salt Spray	14	S	Exposed in Salt Fog for 48 hours. Vertical only.
Magnetic Effect	15	Z	< 0.3 meter
Power Input	16	A & B	for 28 and 14 volt systems
Voltage Spike	17	A	
Audio Frequency Conducted Susceptibility - Power Inputs	18	Z	
Induced Signal Susceptibility	19	C	
Radio Frequency Susceptibility (Radiated and Conducted)	20	UV- [1]	Equipment tested to Category U (Conducted) Equipment tested to Category V (Radiated) No Pulse tests performed.
Emission of Radio Frequency Energy	21	M	
Lightning Induced Transient Susceptibility	22	A3XX	Equipment tested to pin test waveform set A, level 3. No cable bundle test required.
Lightning Direct Effects	23	X	not applicable, no test required
Icing	24	X	not applicable, no test required
Electrostatic Discharge (ESD)	25	A	

[1] The GDL 90 passes Category V (Radiated) for all TSO functions except temporary degraded receiver sensitivity at one frequency in the 2 to 3 GHz band.

A.3 MICRO APM ENVIRONMENTAL QUALIFICATION

The Micro APM has been tested with the GDL 90 to the following environmental categories per procedures defined in RTCA/DO-160D.

Environmental Qualification Form			
Nomenclature: Micro APM Part No.: 430-6200-xxx TSO No.: C154		Manufacturer: Garmin AT 2345 Turner Road SE Salem, Oregon 97302	
Environment	Section	Category	Comment
Temperature and Altitude	4	F1 & A1	Operating temp -20°C to +55°C Short time hi temp to +70°C Ground survival temp -55°C to +85°C Altitude 55,000 feet Decompression 55,000 feet Overpressure Loss of cooling test -- not required
Temperature Variation	5	B	Minimum 5°C per minute
Humidity	6	B	Severe humidity environment.
Operational Shocks and Crash Safety	7	B5R	meets operational and crash safety shock tests 20 Gs at 11 ms.
Vibration	8	S(M & B) U(F & F1)	Standard vibration. Meets without shock mounts. Robust vibration. Meets without shock mounts.
Explosion Proofness	9	X	not applicable, no test required
Waterproofness	10	W	Drip proof test.
Fluids Susceptibility	11	X	not applicable, no test required
Sand and Dust	12	X	not applicable, no test required
Fungus Resistance	13	X	not applicable, no test required
Salt Spray	14	S	Exposed in Salt Fog for 48 hours.
Magnetic Effect	15	Z	< 0.3 meter
Power Input	16	A & B [1]	for 28 and 14 volt systems
Voltage Spike	17	A [1]	
Audio Frequency Conducted Susceptibility - Power Inputs	18	Z [1]	
Induced Signal Susceptibility	19	C	
Radio Frequency Susceptibility (Radiated and Conducted)	20	UV-	Equipment tested to Category U (Conducted) Equipment tested to Category V (Radiated) No Pulse tests performed.
Emission of Radio Frequency Energy	21	M [2]	
Lightning Induced Transient Susceptibility	22	XXXX [2]	not applicable, no test required
Lightning Direct Effects	23	X	not applicable, no test required
Icing	24	X	not applicable, no test required
Electrostatic Discharge (ESD)	25	A	

[1] APM powered by GDL 90. APM not directly exposed to this condition.

[2] Maximum APM wire length 4 inches.

This Page Intentionally Left Blank

APPENDIX B - TROUBLESHOOTING FLOWCHARTS

NOTES

GDL90 Installation Check

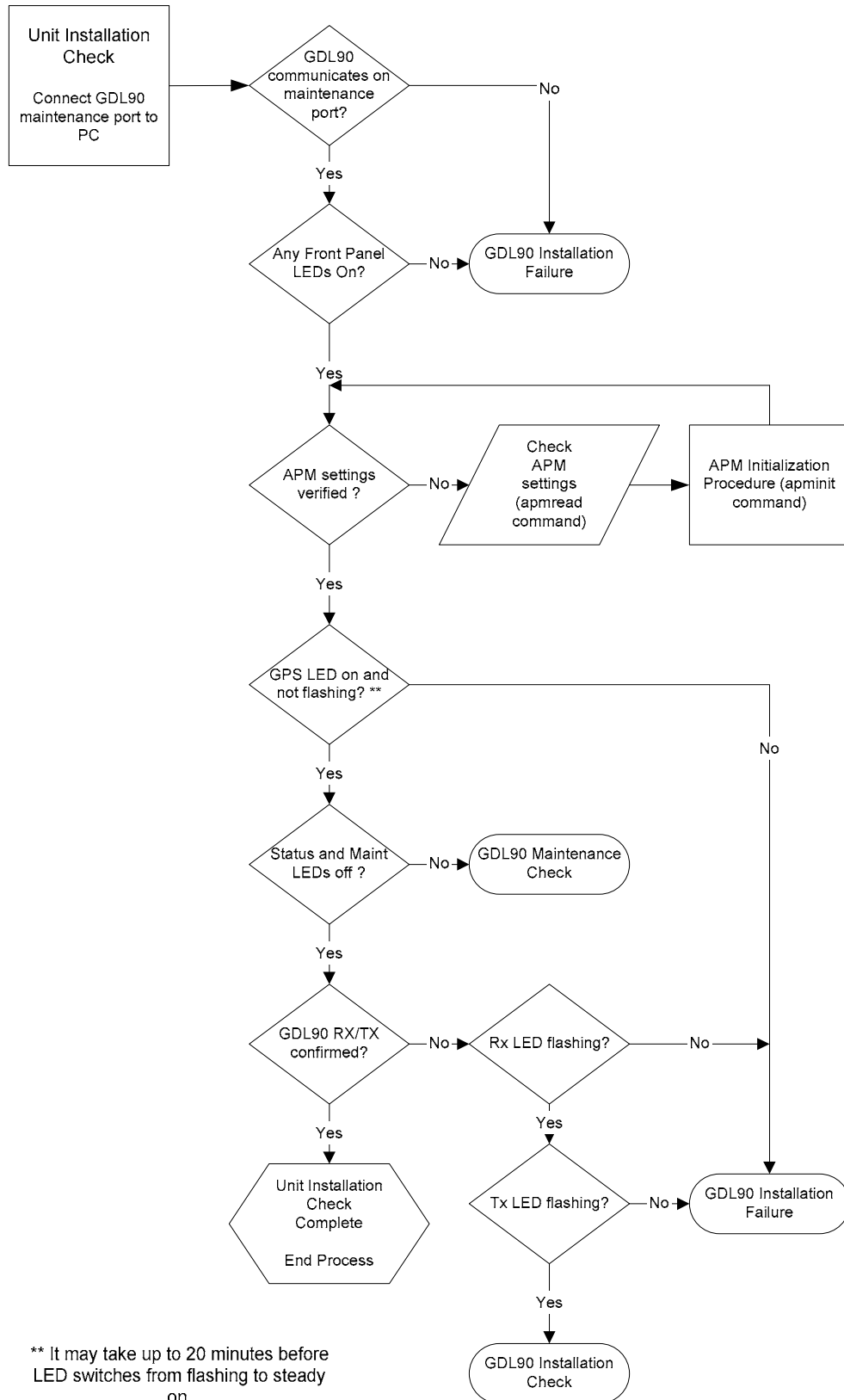

** It may take up to 20 minutes before LED switches from flashing to steady on.

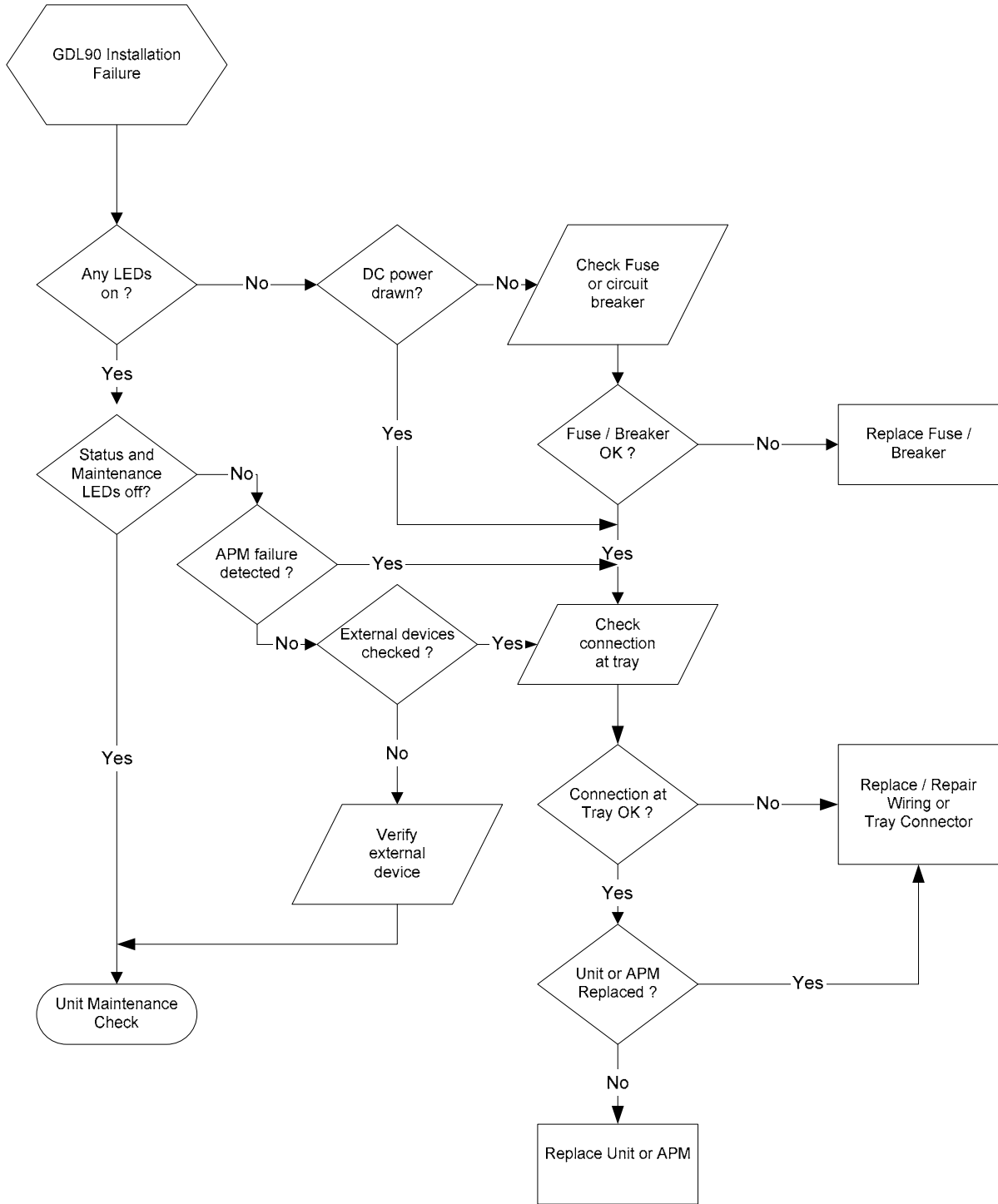

GDL90 Maintenance Check

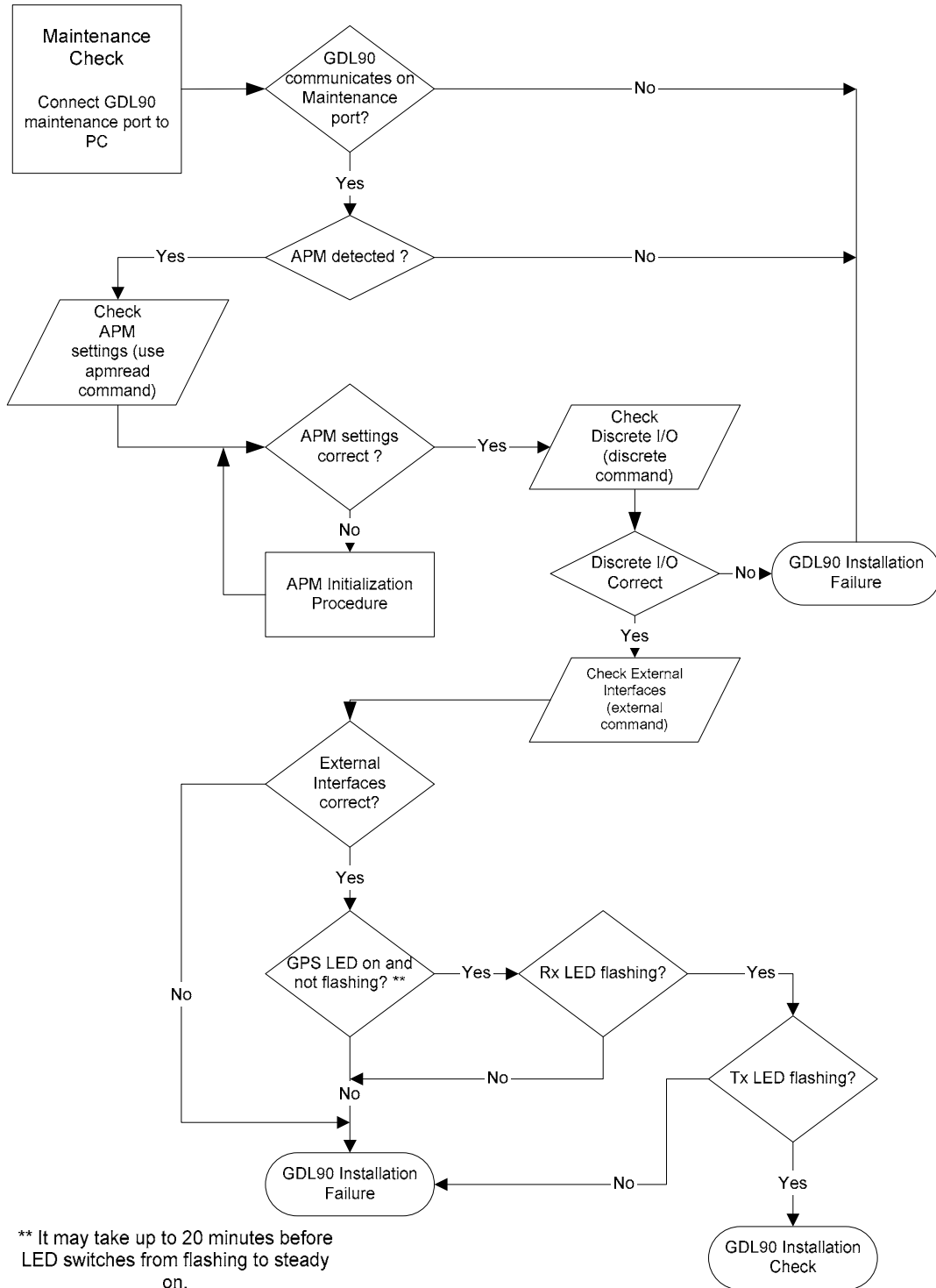

NOTES

APPENDIX C - INTERCONNECT DIAGRAMS

NOTES

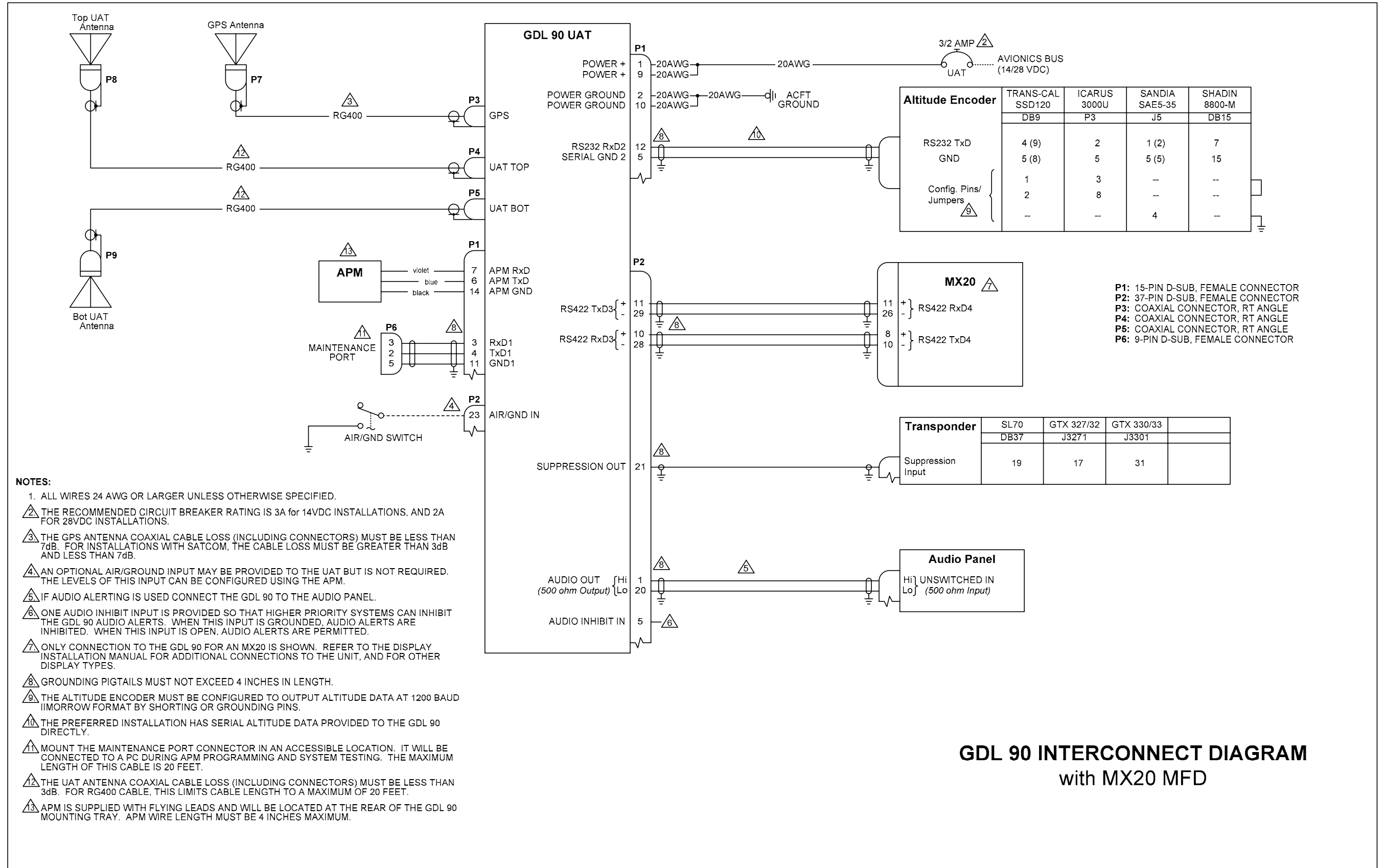

Figure C-1. Interconnect Diagram for installation w/ MX20 MFD

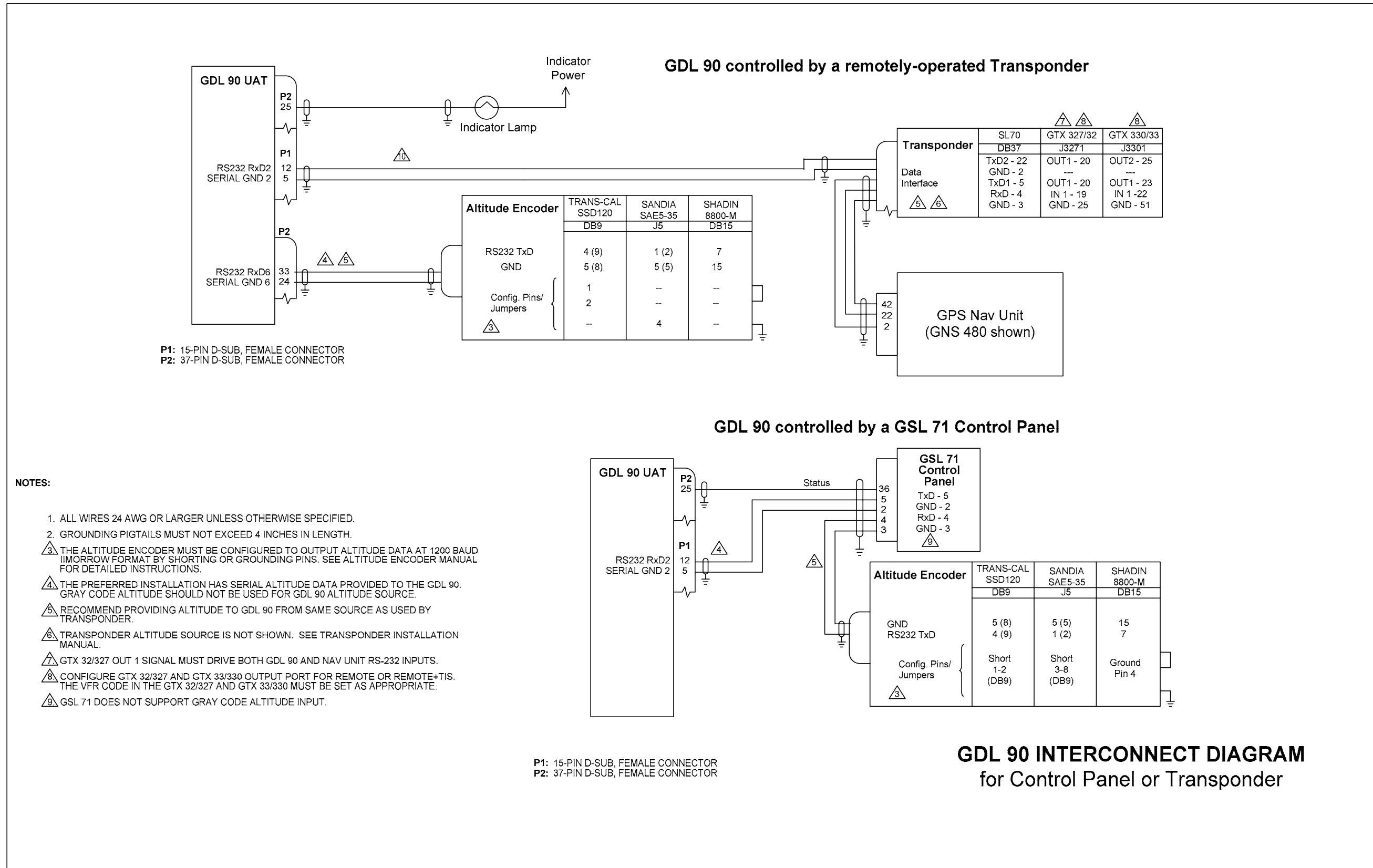

Figure C-2. Interconnect Diagram for Control Panel Installations

APPENDIX D - CONSTRUCTION & VALIDATION OF STRUCTURES

This appendix includes information necessary for testing load-carrying capabilities of equipment mounting structures, such as shelves, mounting plates and mounting brackets, used to mount the GDL 90 mounting tray.

Baggage compartments and cabins or cockpit floors are good mounting platforms providing the floor attachments meet the strength requirements. If support racks, brackets or shelves need to be fabricated, they should be fabricated and attached to the aircraft structure in accordance with the methods outlined in AC 43.13-2A Chapter 2. After the structure is installed, it should be tested as outlined in AC43.13-2A Chapter 1 to verify that it is capable of supporting the required loads.

The GDL 90 installation must be capable of withstanding the Ultimate Load Factors listed in Table D-1 for at least 3 seconds in each direction specified without damage or permanent deformation. Note that these required loads differ somewhat from those normally required for equipment installations.

Since the combined weight of the GDL 90 and its equipment mounting rack is 6.4 lbs, the static loads which must be applied (Load Factor x 6.4 lbs.) will be the following:

Direction of Force	Load Factor	Static Test Load (Load Factor x GDL 90 weight)
Downward	6.6 g	(6.6 x 6.4) = 42.24 lbs
Upward	6.0 g	(6.0 x 6.4) = 38.4 lbs
Sideward	4.5 g	(4.5 x 6.4) = 28.8 lbs
Forward	18.0 g	(18.0 x 6.4) = 115.2 lbs

Table D-1. Static Test Load

One method of determining the static load capability is as follows:

1. Mark and drill the holes where the GDL 90 equipment rack will be mounted.
2. Install four 8-32 machine screws (MS35206, AN526 or equivalent) in the four holes which will be used to mount the GDL 90 equipment rack using washers, nuts and nutplates to mount the equipment rack to the mounting surface. Note: some means of locking fastener must be used, ie. lock nuts & lock washers.
2. For testing downward loading, place shot bags or other suitable weights totaling 42.24 pounds within the footprint outlined by the four screw holes (assuming the mounting surface is horizontal) or use a calibrated force gauge at the location of the center of gravity when the unit is mounted.
3. Verify there is no damage or permanent deformation of the structure after 3 seconds.

5. Fasten a 36 inch loop of suitable material such as fishing line, braided wire, or other similar material having a breaking strength of at least 150 lbs, diagonally between two of the screws. Then fasten another loop diagonally between the other two screws, adjusting the length of the loop so it exactly matches the first.
6. Hook a calibrated force gauge through both loops and apply a sustained pull for at least 3 seconds in each of the other three directions (upward, sideward and forward) at the above calculated forces (i.e. 38.4 lb upward, 28.8 lb sideward and 115.2 lb forward).
7. Examine the support structure carefully. If there has been damage or permanent deformation, the structure is not suitable and must be replaced with one which is strong enough to withstand the test loads. Examine all aircraft stringers, bulkheads and skin surfaces, which may have direct or indirect contact with the fabricated shelf. If it is determined that no damage or permanent deformation has occurred, the structure is of sufficient strength and the GDL 90 equipment rack may be permanently mounted on it.

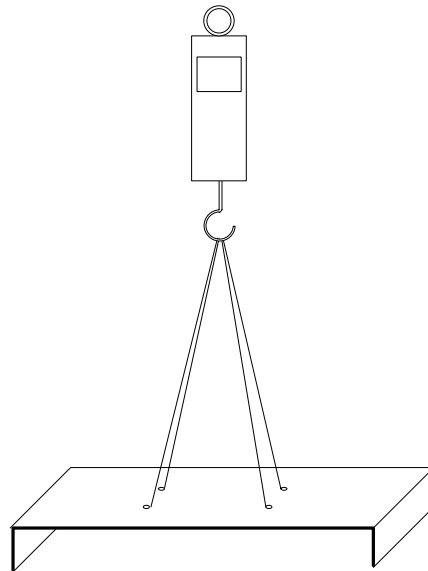

Figure D-3. Upward Static Load Test

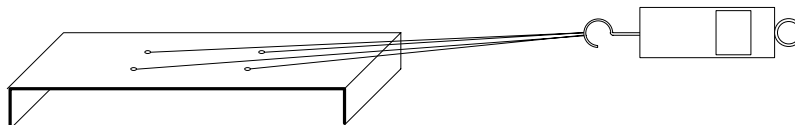

Figure D-4. Forward Static Load Test

